



New South Wales

Marine Safety Regulation 2015

under the

Marine Safety Act 1998

[If this Regulation is made, the following enacting formula will be included:]

His Excellency the Governor, with the advice of the Executive Council, has made the following Regulation under the *Marine Safety Act 1998*.

Minister for Roads, Maritime and Freight

Explanatory note

The object of this Regulation is to remake, with some amendments, the provisions of the *Marine Safety (General) Regulation 2009* which is repealed on 1 September 2015 by section 10 (2) of the *Subordinate Legislation Act 1989*.

This Regulation makes provision with respect to the following:

- (a) craft that are not “vessels” for the purposes of the *Marine Safety Act 1998*,
- (b) the safety of navigation, including the following:
 - (i) the adoption of the *International Regulations for Preventing Collisions at Sea* (with modifications),
 - (ii) signals and lights on vessels,
 - (iii) the conduct of persons on board vessels,
 - (iv) the operation and securing of vessels,
 - (v) the obstruction of navigation,
 - (vi) speed limits for certain areas,
 - (vii) requirements relating to distances between vessels and other objects,
 - (viii) the towing of persons,
 - (ix) personal watercraft,
 - (x) the safe loading of vessels,
- (c) special navigation requirements for commercial adventure vessels,
- (d) special navigation requirements for navigation in the vicinity of Lord Howe Island and in Sydney Cove,
- (e) requirements relating to builders plates for certain recreational vessels,
- (f) marine safety licences, including the following:

public consultation draft

Marine Safety Regulation 2015 [NSW]
Explanatory note

- (i) general provisions,
- (ii) vessel registration,
- (iii) aquatic licences,
- (iv) boat driving licences,
- (g) the safety equipment that must be carried on vessels,
- (h) requirements for the wearing of lifejackets,
- (i) requirements for hatches and exterior doors,
- (j) the inspection and maintenance of public ferry wharves,
- (k) the security of blood and urine samples taken for alcohol and drug testing,
- (l) the offences that may be dealt with by way of penalty notice and the penalties for those offences when dealt with in that way,
- (m) the fees payable for certain services,
- (n) exemptions from provisions of the Regulation,
- (o) savings and formal matters.

This Regulation is made under the *Marine Safety Act 1998*, including sections 5 (3), 9M, 10 (2), 11, 16, 29 (h), 38 (1) (c), 50 (3), 99, 126, 137 (the general regulation-making power) and 139 (1) and clause 1 of Schedule 4.

public consultation draft

Marine Safety Regulation 2015 [NSW]
Contents

Contents

	Page
Part 1 Preliminary	
1 Name of Regulation	8
2 Commencement	8
3 Definitions	8
4 Definition of “vessel” for purposes of Act	11
Part 2 Safety of navigation	
Division 1 Regulations for prevention of collisions at sea or in other navigable waters	
5 Adoption of international regulations	12
Division 2 Other provisions relating to signals and lights on vessels	
6 Restrictions on making distress signals	12
7 Display of emergency patrol signal	12
Division 3 Conduct of persons on board vessels	
8 Requirements for keeping all parts of the body within a vessel when underway	13
9 Directions to ensure safety of commercial vessel	13
10 Offences by passengers and others on commercial vessels	14
Division 4 Provisions relating to operation and securing of vessels	
11 General provisions that apply to operation of vessels	15
12 Speed restriction where persons under 18 years on vessel	15
13 Requirements in relation to engine power rating	15
14 Requirements when towing or pushing a vessel or object	15
15 Waters in which kitesurfing and sailboarding prohibited	15
16 Exemptions from notices prohibiting or regulating operation of vessels	16
17 Restrictions on wake boats	16
Division 5 Provisions relating to obstruction of navigation	
18 Obstruction of fairways and channels	16
19 Restrictions on obstructing vessels	16
20 Restrictions on causing an obstruction, danger or nuisance with objects	16
21 Lighting and marking obstructions to navigation	17
22 Disposal of obstructions to navigation	17
23 Obligation on operators if vessels cause an obstruction to navigation	18
24 Obstruction of lighthouses, lightships or dolphins	18
25 Securing vessel to navigation aid or bridge	18
26 Restrictions near certain vessels or machinery	18
27 Restrictions near certain wharves or marine installations	19
28 Restrictions near construction work	19
29 Climbing on vessels	20
30 Restrictions near naval vessels	20
31 Restrictions on securing vessels and interfering with safety equipment	20

public consultation draft

	Page
Division 6 Speed limits for certain areas	
32 Application of Division where notice applies	21
33 Speed limit for Port of Sydney Central Area	21
34 Speed limit for Port of Sydney Northern Area	21
35 Speed limit for Port of Sydney Western Area	21
36 Speed limit of 8 knots	22
Division 7 Requirements relating to distances between vessels and other objects	
37 Meaning of “safe distance”	22
38 Minimum distances to be maintained	22
39 Restrictions in or near swimming areas	23
40 Special provisions for vessels in the vicinity of vessels operating in chains	23
Division 8 Towing of persons	
41 Restriction on number of persons that can be towed	24
42 Restriction on time of day when towing can occur	24
43 Speed restriction where persons being towed is under 18 years	24
44 Observer requirements	24
45 Responsibilities in relation to trailing equipment	25
46 Tow rope and towing device requirements	25
Division 9 Personal watercraft	
47 Personal watercraft behaviour label	26
48 Personal watercraft excluded from Sydney Harbour and its tributaries	26
49 Operation of personal watercraft at any speed	27
50 Operation of personal watercraft between sunset and sunrise	27
Division 10 Safe loading of vessels	
51 Maximum safe loading level of certain vessels	28
52 Maximum safe loading levels for personal watercraft	29
Part 3 Special safety requirements for certain waters and vessels	
Division 1 Waterway management	
53 Operation of commercial vessels in State waters	30
Division 2 Navigation requirements for commercial adventure vessels	
54 Definitions	30
55 Speed requirements for commercial adventure vessels in Port Jackson waters	30
56 Navigation requirements for commercial adventure vessels operating in irregular manner	31
Division 3 Requirements for navigation in the vicinity of Lord Howe Island	
57 Navigation requirements for certain vessels	31
Division 4 Requirements for navigation in Sydney Cove	
58 Requirements for master of vessel operating in Sydney Cove	31

Part 4 Requirements relating to builders plates for certain recreational vessels

Division 1 Preliminary

59	Definitions	32
60	Application of Part	32
61	Variation of ABP Standard	33

Division 2 Requirements relating to builders plates

62	Vessel for sale required to have builders plate	33
63	Builders plate exemptions—available defences	34
64	Persons authorised to approve information on builders plates	34
65	Offences relating to fixing of builders plates on vessels	34
66	Offence relating to approval of information on builders plates	35
67	Builders plate not to be altered unless authorised	35
68	Vessel may not be registered without builders plate	35

Part 5 Marine safety licences

Division 1 General provisions

69	Definition	36
70	Declaration of certain marine safety licences	36
71	Applications for marine safety licences	36
72	Eligibility for licence	36
73	Refusal to issue marine safety licence	37
74	When immediate boat driving licence suspension notice may be issued	37
75	Suspension or cancellation of marine safety licence	39
76	Disqualification of person from holding or obtaining marine safety licence	40
77	Change of particulars to a marine safety licence	40
78	Issue of replacement marine safety licence	41
79	Renewal of marine safety licence	41
80	Return of a marine safety licence	41
81	Cheating or forgery	41

Division 2 Vessel registration

82	Vessels exempt from registration	42
83	Vessel registration number issued on initial registration of vessel	43
84	Hull identification number requirements	43
85	Boatcode agents	44
86	Alteration of a hull identification number	44
87	Display of vessel registration number	44
88	Removal of vessel registration number	44
89	Personalised vessel registration	44
90	Transfer of registrable vessel ownership	45
91	Disposal of a registrable vessel	45
92	Condition of personal watercraft registration relating to unlicensed operation of watercraft	45
93	Unauthorised operation of vessel	45

public consultation draft

	Page
Division 3 Aquatic licences	
94 Aquatic activities to be licensed	45
95 Classification of aquatic licences	46
96 Purpose of aquatic licences	46
97 Additional requirements for applications	46
Division 4 Boat driving licences	
98 Classification of boat driving licences	47
99 Certain vessels and persons exempt from requirements relating to boat driving licences	47
100 Licence requirements for hire and drive vessels	48
101 Additional requirements for applications for boat driving licences	48
102 Conditions of boat driving licences	48
103 Restrictions applying to boat driving licence holders under 16 years	49
104 Disqualification of certain persons from holding boat driving licences	49
Division 5 Marine pilot's licences	
105 Additional requirements for applications for marine pilot's licences	50
106 Conditions of marine pilot's licences	50
Division 6 Marine pilotage exemption certificates	
107 Additional requirements for applications for marine pilotage exemption certificates	51
108 Conditions of marine pilotage exemption certificates	51
109 Vessels for which marine pilot exemption certificates are not valid	51
Division 7 Certificates of local knowledge	
110 Additional requirements for applications for certificates of local knowledge	52
111 Conditions of certificates of local knowledge	52
112 Vessels for which certificates of local knowledge are not valid	52
Division 8 Bar crossings by certain commercial vessels	
113 Application of Part	53
114 Authorisation required for bar crossings for certain commercial vessels	53
115 Requirements on masters of certain commercial vessels in relation to bar crossings	53
Part 6 Safety equipment and facilities	
Division 1 Preliminary	
116 Vessels exempt from certain requirements of Part	54
117 Meaning of "appropriate lifejacket"	54
Division 2 Responsibilities of owners and operators of recreational vessels in relation to safety equipment	
118 Minimum safety equipment to be carried on recreational vessels	55
Division 3 Requirements to wear lifejackets	
119 Application of Division	56
120 Circumstances in which lifejacket must be worn on board certain vessels	56

public consultation draft

Marine Safety Regulation 2015 [NSW]
Contents

	Page	
121	Circumstances in which lifejacket must be worn on board a vessel under 4.8 metres in length	56
122	Lifejacket must be worn when crossing coastal bar	57
123	Lifejacket must be worn on personal watercraft	57
124	Lifejacket must be worn by a child less than 12 years of age	57
125	Lifejacket must be worn when being towed by a vessel while engaged in any recreational activity	57
126	Lifejacket must be worn when directed by master of a vessel	58
127	General defences	58
Division 4 Requirements for hatches and exterior doors		
128	Hatches and exterior doors—construction	58
129	Hatches and exterior doors—locking	58
Division 5 Kill switches		
130	Kill switch must be operated if available	58
Part 7 Miscellaneous		
131	Inspection reports on public ferry wharves	60
132	Maintenance plans for public ferry wharves	60
133	Security of blood and urine samples taken under Part 2, 3, 4 or 5 of Schedule 1 to the Act	60
134	Penalty notice offences and penalties	61
135	Fees	62
136	No false representation as to whether navigation is restricted in an area	62
137	Report of certain accidents	62
138	Exemption on safety or emergency grounds	62
139	Exemptions by RMS	63
140	Savings and repeal	63
Schedule 1	Fees relating to State matters	64
Schedule 2	Fees relating to National law matters	67
Schedule 3	Partially smooth waters	70
Schedule 4	Smooth waters	71
Schedule 5	Modifications to International Regulations for Preventing Collisions at Sea	76
Schedule 6	Waters in which kitesurfing and sailboarding prohibited	79
Schedule 7	Requirements relating to Sydney Cove	81
Schedule 8	Minimum safety equipment to be carried on recreational vessels	84
Schedule 9	Standard of safety equipment carried on recreational vessels	88
Schedule 10	Coastal bars	92
Schedule 11	Penalty notice offences—offences under Marine Safety Act 1998	95
Schedule 12	Penalty notice offences—offences under Marine Pollution Act 2012	99

Marine Safety Regulation 2015

under the

Marine Safety Act 1998

Part 1 Preliminary

1 Name of Regulation

This Regulation is the *Marine Safety Regulation 2015*.

2 Commencement

This Regulation commences on 1 September 2015 and is required to be published on the NSW legislation website.

Note. This Regulation replaces the *Marine Safety (General) Regulation 2009*, which is repealed on 1 September 2015 by section 10 (2) of the *Subordinate Legislation Act 1989*.

3 Definitions

(1) In this Regulation:

aerial equipment means equipment by means of which a person is towed, whether by a vessel or otherwise, over water.

alpine waters means:

(a) the waters of any of the following:

- (i) Lake Burrinjuck,
- (ii) Lake Eucumbene,
- (iii) Lake Jindabyne,
- (iv) Khancoban Pondage,
- (v) the Swampy Plains River,
- (vi) Mannus Lake,
- (vii) Googong Reservoir,
- (viii) Blowering Reservoir,
- (ix) Pejar Dam,
- (x) Yass River,
- (xi) Lake Oberon, and

(b) all navigable waters within the boundaries of the Kosciuszko National Park.

appropriate lifejacket—see clause 117.

aquatic activity has the same meaning as in section 18 of the Act.

aquatic licence means an aquatic licence issued under Part 5 as either of the following:

- (a) a licence for commercial aquatic activities,
- (b) a licence for all other (non-commercial) aquatic activities.

boat driving licence means a marine safety licence referred to in section 29 (e) of the Act and issued under Part 5 as either of the following:

- (a) a general boat driving licence,
- (b) a personal watercraft driving licence.

channel means an area of navigable waters that, whether or not indicated by navigation marks, provides a passage for vessels.

coastal bar means a bar named in Schedule 10, being a shallow area where sediment is deposited across a river mouth, lake, estuary or harbour entrance, and any channel through or around the shallow area, in the approximate location described opposite the name of the bar in that Schedule.

current first aid certificate means a first aid certificate of a type approved by RMS that is in force.

diver means a person using or carrying self-contained underwater breathing apparatus (scuba) or any other form of breathing apparatus either under or on the surface of the water.

diverting means making an abrupt or sudden change of direction at speed.

dolphin means a free standing pile or cluster of piles, acting as a fender or mooring point.

dragon boat means a paddle craft that is carvel constructed and consists of a single hull and a keel tunnel, and is propelled forward by a crew of paddlers using single bladed paddles.

enclosed waters means navigable waters within the land mass of New South Wales such as inland and coastal rivers, inland and coastal lakes and similar waters, and enclosed coastal bays and harbours and includes the waters specified in Schedules 3 and 4.

EPIRB means an emergency position indicating radio beacon.

fairway means that part of an area of navigable waters that is usually used by vessels for navigation through the area.

ferry and **ferry service** have the same meaning as in the *Passenger Transport Act 2014*.

Note. The *Passenger Transport Act 2014* defines **ferry** as a vessel which seats more than 8 adult persons, and includes a vessel of any class prescribed by the regulations under that Act for the purposes of that definition.

floating object includes any floating cargo, goods or things.

fuel means any solid, liquid or gaseous matter intended for use as a fuel in powering a vessel, or carrying out any function on a vessel.

hull identification number means a hull identification number referred to in clause 84.

kiteboard means any watercraft used for kitesurfing.

kitesurfing means an activity in which a person is situated on or over water on a board, a ski or skis or a vessel and the power of a controllable kite, or similar equipment, is used to propel the person across the surface of the water and includes kiteboarding, flysurfing, kitesailing and the like.

label includes a sticker or a plate.

length of a vessel means the centreline measurement of the hull of the vessel taken from a point at the top of the stern to the top of the bow (but excluding any extension that is not an integral part of the hull, such as a bowsprit, outboard motor bracket or outboard motor pod).

marine legislation means any of the following Acts (and the regulations and other instruments made under any of those Acts):

public consultation draft

Marine Safety Regulation 2015 [NSW]
Part 1 Preliminary

- (a) the Act,
- (b) the *Ports and Maritime Administration Act 1995*,
- (c) the *Marine Pollution Act 2012*,
- (d) the *Maritime Services Act 1935*.

mooring means an apparatus or structure to which a vessel or floating object may be secured.

off-the-beach vessel means an unballasted, sail-only vessel, including a centreboard dinghy, skiff or multihull vessel, but not including a vessel with a cabin or a fixed keel.

open waters means navigable waters that are not enclosed waters.

outrigger canoe means a single file canoe which possesses a float and lateral support on one or both sides of the main hull and which is designed to carry not more than 6 persons.

parasailing vessel means a power-driven vessel used to tow a person over water using aerial equipment.

partially smooth waters means waters specified in Schedule 3.

passenger means any person on board a vessel who is neither the operator nor a member of the crew.

person authorised to approve information means a person referred to in clause 64.

personal watercraft means a power-driven vessel that:

- (a) has a fully enclosed hull, and
- (b) does not retain water taken on if it capsizes, and
- (c) is designed to be operated by a person lying, standing, sitting astride or kneeling on the vessel but not seated within the vessel,

and includes a jet powered surfboard.

port means any port (within the meaning of section 84 of the Act) for which the Minister has appointed a harbour master, or a person to exercise the functions of a harbour master, under the Act.

power-driven vessel means a vessel powered by mechanical means and includes a canoe, kayak or row boat fitted with a motor.

public wharf means any wharf open to, or permitted to be used by, the public.

registered vessel means a vessel that is the subject of a vessel registration certificate in force under this Regulation.

relevant fee, in relation to a matter referred to in this Regulation, means the fee specified in Schedule 1 in relation to the matter.

row boat means a vessel propelled by oars or paddles that is not a canoe, kayak or rowing shell.

sailboard means any craft (other than a kiteboard) used for sailboarding or windsurfing, which is fitted with an apparatus or mechanism that is required to be controlled or operated by the user in order to harness the power of the wind to move the craft.

sailing vessel means a vessel operating under sail only.

seagoing ship means a vessel of more than 45.72 metres in length that is used or intended to be used to carry cargo or passengers for hire or reward and that normally operates on voyages between ports.

shipping mooring means a buoy, dolphin or other mooring provided for seagoing ships.

smooth waters means waters specified in Schedule 4.

special event has the same meaning as in section 12 of the Act.

speed means the speed of a vessel measured by reference to the actual distance travelled over the ground.

structure includes any object that is fixed to the earth or seabed, or to another object fixed to the earth or seabed, or any rubble or reclamation.

tender means a vessel that:

- (a) is used only to transport goods or persons between the shore and its parent vessel or between its parent vessel and another vessel, and
- (b) does not operate further from its parent vessel than 1 nautical mile, and
- (c) is less than 7.5 metres in length.

the Act means the *Marine Safety Act 1998*.

tow rope means a rope or other thing that connects a person being towed, a towing device or a towed apparatus to a power-driven vessel.

tow-in surfing means an activity in which a personal watercraft is used to tow a person on a surfboard onto a wave.

underway means not at anchor or secured to the shore or ground, and includes drifting.

unpowered vessel means:

- (a) a vessel without an engine, or
- (b) a vessel that is fitted with an engine that is turned off and that is being propelled by other means (such as sail).

vessel in chains means a ferry, or similar vessel, operating in chains, ropes or cables across a waterway.

wash means the movement of water created by a vessel.

wear, in relation to a lifejacket, means wear with all closing or fastening devices such as zippers, buckles and tapes correctly secured.

wharf includes a pier, jetty, landing stage, dock, slip or platform.

- (2) For the purpose of this Regulation, a recreational vessel being transferred from one location to another is not a commercial vessel (regardless of whether or not money, or other consideration, is received for the transfer) if fare-paying passengers are not being carried on the vessel.
- (3) For the purposes of this Regulation, a reference to a specified class of vessel is a reference to that class of service category as described in Clause 3.5 of Chapter 3 of Part B of the document titled the *National Standard for Commercial Vessels* adopted by the former Australian Transport Council and as in force from time to time.
- (4) Notes included in this Regulation do not form part of this Regulation.

4 Definition of “vessel” for purposes of Act

- (1) Any craft used on water that is capable of being used underwater is declared to be a vessel.
- (2) Any pontoon, airdock, floating dock or similar apparatus, or any floating apparatus used as an accessory in surfing or bathing or used as flotation equipment by a person being towed by a vessel, is declared not to be a vessel unless it is a kiteboard or a sailboard.

Part 2 Safety of navigation

Division 1 Regulations for prevention of collisions at sea or in other navigable waters

5 Adoption of international regulations

For the purposes of section 10 (2) of the Act, the *International Regulations for Preventing Collisions at Sea 1972* published by the International Maritime Organization are adopted with the modifications set out in Schedule 5.

Division 2 Other provisions relating to signals and lights on vessels

6 Restrictions on making distress signals

- (1) A person on board a vessel, or in the vicinity of any navigable waters, must not use distress signalling equipment or make any distress signal, except for the purpose of indicating distress.
Maximum penalty: 50 penalty units.
- (2) A person must not, without proper cause, display or make any light or other visual signal, or any sound signal, that is used as a warning or guide to vessels.
Maximum penalty: 50 penalty units.
- (3) The operator of a vessel must ensure that each person on board the vessel complies with this clause.
Maximum penalty: 50 penalty units.

7 Display of emergency patrol signal

- (1) A person must not operate a vessel that displays an emergency patrol signal unless:
 - (a) the display has been authorised in writing by RMS for the purpose of enabling the carrying out of emergency patrol duty, or
 - (b) the vessel is operated on behalf of RMS, the NSW Police Force, the Ambulance Service of NSW or a fire service for the purpose of carrying out an emergency patrol duty, or
 - (c) the vessel is operated on behalf of Marine Rescue NSW for the purpose of carrying out any emergency patrol duty.Maximum penalty: 50 penalty units.
- (2) An operator of a vessel carrying out an emergency patrol duty must ensure that an emergency patrol signal is displayed in a clearly visible position if directed to do so by RMS.
Maximum penalty: 50 penalty units.
- (3) An operator of a vessel must comply with any direction concerning the manner of navigation of the vessel given by the operator or any crew member of another vessel displaying an emergency patrol signal in accordance with this clause.
Maximum penalty: 50 penalty units.
- (4) In this clause:
emergency patrol duty means an urgent patrol or duty arising from an accident, hazard or other emergency or authorised by RMS.
emergency patrol signal means an all-round flashing blue light, or flashing blue and red lights.

Division 3 Conduct of persons on board vessels

8 Requirements for keeping all parts of the body within a vessel when underway

- (1) This clause does not apply to:
 - (a) commercial vessels that are not hire and drive vessels, or
 - (b) a regulated Australian vessel or vessel regulated under the *Navigation Act 2012* of the Commonwealth.
- (2) The operator of a power-driven vessel must not permit any person on board the vessel to extend any part of that person's body outside the perimeter of the vessel while the vessel is making way.
Maximum penalty: 50 penalty units.
- (3) The operator of a power-driven vessel must not allow a person to be on the bow of the vessel, in a position that puts the person at increased risk of falling overboard, while the vessel is making way.
Maximum penalty: 50 penalty units.
- (4) A person on board a power-driven vessel must not extend any part of the person's body outside the perimeter of the vessel while the vessel is making way.
Maximum penalty: 50 penalty units.
- (5) A person must not be on the bow of a power-driven vessel, in a position that puts the person at increased risk of falling overboard, while the vessel is making way.
Maximum penalty: 50 penalty units.
- (6) The operator of a power-driven vessel that is making way must not permit any person to sit on, ride on or hang onto a swim ladder, swim platform or transom attached to the vessel.
Maximum penalty: 50 penalty units.
- (7) A person on board a power-driven vessel that is making way must not sit on, ride on or hang onto a swim ladder, swim platform or transom attached to the vessel.
Maximum penalty: 50 penalty units.
- (8) This clause does not apply to a person who is:
 - (a) anchoring, mooring or casting off, or
 - (b) fishing while the vessel is anchored, moored or drifting, or
 - (c) involved in any activity relating to securing the safety of any person or property, or
 - (d) the operator of, or a passenger on, a personal watercraft.
- (9) In this clause, a reference to a vessel making way is a reference to the vessel being underway and propelled by the vessel's machinery.

9 Directions to ensure safety of commercial vessel

- (1) An authorised person for a commercial vessel may give a direction to a person not to board or remain on board the vessel if the authorised person is of the opinion that the direction is necessary to ensure that the maximum number of persons that the vessel is authorised to carry is not exceeded.
- (2) An authorised person for a commercial vessel may give a direction to a person not to enter or remain in a part of the vessel if the authorised person is of the opinion that the direction is necessary to ensure that the maximum number of persons authorised to be carried in that part of the vessel is not exceeded.

- (3) An authorised person for a commercial vessel may give a direction to a person who is a passenger or special personnel on the vessel to move to or from a part of the vessel, or cease an activity in which the person is engaged on the vessel, if the authorised person is of the opinion that the direction is necessary to ensure the proper and orderly management, operation or navigation of the vessel.
- (4) A person must not fail to comply with any reasonable direction given to the person under this clause.
Maximum penalty: 50 penalty units.
- (5) An authorised person may not give a direction under this clause to a relevant officer who is exercising his or her functions as a relevant officer.
- (6) In this clause:
authorised person for a commercial vessel means a person on board the vessel who is concerned in the navigation, operation or management of the vessel and includes, for the purposes of subclauses (1) and (2), a person who is concerned in the conduct of operations at the berth of the vessel.
relevant officer means:
(a) a police officer, or
(b) an officer of a Department of the New South Wales Government or the Commonwealth Government, or
(c) an officer of a statutory authority created under the law of New South Wales or of the Commonwealth.
special personnel means all persons who:
(a) have knowledge of safety procedures and the handling of safety equipment on board, and
(b) are not passengers, or members of the crew, or children under one year of age, and
(c) are carried on board in connection with the special purpose of that vessel, or because of special work being carried out aboard that vessel, and
(d) are able bodied.

10 Offences by passengers and others on commercial vessels

- (1) A passenger on a commercial vessel must not:
(a) be in a part of the vessel if there is a notice displayed at each place on the vessel designed for entry to that part that prohibits the passenger's entry to that part, or
(b) be on any roof, awning or mast on the vessel.
Maximum penalty: 50 penalty units.
- (2) A person on a commercial vessel must not:
(a) obstruct a person engaged in the navigation or other operation of the vessel, or
(b) wilfully damage, or use for a purpose for which it was not intended, any part of the vessel or any equipment on the vessel, or
(c) remove, damage or deface any sign or notice on the vessel that relates to the vessel's safe and proper use.
Maximum penalty: 50 penalty units.

Division 4 Provisions relating to operation and securing of vessels

11 General provisions that apply to operation of vessels

- (1) The operator of a vessel must not drive the vessel through the space provided by the lifting or lateral movement of the opening span of a bridge unless the vessel is a power-driven vessel or is being towed or pushed by a power-driven vessel.

Maximum penalty: 50 penalty units.

- (2) The operator of a vessel must not cause wash that damages or impacts unreasonably on:

- (a) any dredge or floating plant, or
- (b) any construction or other works in progress, or
- (c) any bank, shore or waterside structure, or
- (d) any other vessel, including a vessel that is moored.

Maximum penalty: 50 penalty units.

12 Speed restriction where persons under 18 years on vessel

- (1) The operator of a vessel must not operate the vessel at a speed of more than 60 knots if any person under the age of 18 years is on board the vessel.

Maximum penalty: 50 penalty units.

- (2) This clause does not apply to a vessel operated in accordance with an aquatic licence.

13 Requirements in relation to engine power rating

The owner and master of a vessel are each guilty of an offence if the vessel is operated while having a motor that exceeds:

- (a) the power rating specified for the vessel by the manufacturer, or
- (b) if there is no power rating specified for the vessel by the manufacturer or the power rating is not apparent:
 - (i) in the case of a vessel with an outboard motor, the maximum power capacity as calculated in accordance with section 2.6 of AS 1799.1—2009 *Small craft—General requirements for power boats*, or
 - (ii) in any other case, the power rating (if any) approved by RMS for vessels of that kind.

Maximum penalty: 50 penalty units.

14 Requirements when towing or pushing a vessel or object

The operator of a vessel engaged in towing or pushing another vessel or object must ensure that the vessel or object being towed or pushed is:

- (a) safely secured to the towing or pushing vessel during the period of the tow, and
- (b) positioned so that the vessel or object, or anything on the vessel or object, does not obscure visibility from the towing or pushing vessel unless a person appropriately positioned is providing safety instructions to the operator.

Maximum penalty: 50 penalty units.

15 Waters in which kitesurfing and sailboarding prohibited

- (1) A person must not engage in kitesurfing in any waters specified in Part 1 of Schedule 6.

Maximum penalty: 50 penalty units.

- (2) A person must not engage in sailboarding in any waters specified in Part 2 of Schedule 6.
Maximum penalty: 50 penalty units.

16 Exemptions from notices prohibiting or regulating operation of vessels

- (1) The following vessels are exempt from compliance with a notice displayed under section 11 of the Act:
- (a) a vessel operated by a police officer, or an officer or member of staff of RMS, acting in the exercise of his or her functions,
 - (b) a vessel operated in waters or in a manner that does not comply with the notice in order to avoid an immediate risk of injuring persons or damaging property.
- (2) A vessel that is not a power-driven vessel is exempt from compliance with a notice displayed under section 11 of the Act to the extent that the notice contains restrictions on the speed of vessels.

17 Restrictions on wake boats

A person must not operate a power-driven vessel that is ballasted at low speed, or uses some other method, so as to generate a large wave or wake for the purposes of wakeboarding or wake surfing activities in any area of navigable waters where such operation is prohibited by the display of notices erected by RMS.
Maximum penalty: 50 penalty units.

Division 5 Provisions relating to obstruction of navigation

18 Obstruction of fairways and channels

The operator of a vessel must not:

- (a) obstruct, or restrict or impede access to, any fairway or channel, or
- (b) obstruct the approach to, or restrict or impede the proper use of, any wharf or other landing place, or any boatshed, launching ramp or courtesy or emergency mooring.

Maximum penalty: 50 penalty units.

19 Restrictions on obstructing vessels

A person must not obstruct or in any way impede:

- (a) the launching, removal from the water or securing of a vessel, or
- (b) the handling of cargo or the embarking or disembarking of passengers in respect of a vessel, or
- (c) the safe navigation of a vessel.

Maximum penalty: 50 penalty units.

20 Restrictions on causing an obstruction, danger or nuisance with objects

- (1) A person must not cause any object or apparatus to float on, extend over or be in any navigable waters if it:
- (a) obstructs, or is likely to obstruct, navigation, or
 - (b) causes, or is likely to cause, nuisance or danger to any person, or
 - (c) causes, or is likely to cause, damage to any property.
- Maximum penalty: 50 penalty units.

- (2) A person must not throw or otherwise project into, or cause to extend over or into, any navigable waters any object or apparatus that:
 - (a) obstructs, or is likely to obstruct, navigation, or
 - (b) causes, or is likely to cause, any nuisance or danger to any person, or
 - (c) causes, or is likely to cause, damage to any property.Maximum penalty: 50 penalty units.

21 Lighting and marking obstructions to navigation

- (1) The owner of any obstruction to navigation must ensure that it is marked and lit so that it does not cause a danger to navigation.
Maximum penalty: 50 penalty units.
- (2) RMS may, in writing, direct the owner of an obstruction to navigation to mark or light the obstruction in the time and manner specified in the direction and to maintain the marking or lighting in good condition.
- (3) The owner of an obstruction to navigation to whom a direction is given under subclause (2) must comply with that direction.
Maximum penalty: 50 penalty units.
- (4) The owner of an obstruction to navigation to whom a direction is given under subclause (2) must notify RMS as soon as the owner becomes aware of any defect in relation to the marking or lighting of the obstruction.
Maximum penalty: 50 penalty units.
- (5) If the owner of any obstruction to navigation fails to comply with a direction under subclause (2), RMS may take action to cause the obstruction to be marked or lit.
- (6) RMS may recover as a debt in a court of competent jurisdiction the reasonable costs and expenses incurred by RMS in the exercise of its powers under subclause (5) from the owner of the obstruction to navigation.
- (7) In this clause:

obstruction to navigation means anything in, over or on navigable waters (including a vessel, whether wrecked or not) that:

 - (a) is a danger to the safe navigation of vessels (whether or not it is lawfully erected in, over or on navigable waters), or
 - (b) is moored, berthed or placed in contravention of the marine legislation or the National Law.

22 Disposal of obstructions to navigation

- (1) The Minister may dispose of any obstruction to navigation removed under section 16 of the Act in accordance with this clause.

Note. Section 16 of the Act enables the Minister to direct the owner or person responsible for an obstruction to navigation to remove the obstruction. If the person fails to do so, the Minister may remove or authorise the removal of the obstruction.
- (2) The Minister is to take reasonable steps to determine who is the owner or person responsible for the obstruction to navigation unless the obstruction has been destroyed as referred to in section 16 (3) of the Act or the Minister considers the obstruction has no appreciable market value.
- (3) If the Minister considers that the obstruction to navigation has no appreciable market value, the Minister may direct that the obstruction be disposed of, kept, repaired or treated in any way that the Minister considers appropriate.

- (4) If the Minister considers that the obstruction to navigation has some appreciable market value, the obstruction is to be returned to a person who:
 - (a) establishes to the satisfaction of the Minister that the person is the owner or person responsible for the obstruction, and
 - (b) pays to the Minister the amount of reasonable costs and expenses incurred by the Minister as referred to in section 16 (5) of the Act.
- (5) If the Minister is unable to establish who is the owner or person responsible for the obstruction to navigation or recover the amount of reasonable costs and expenses incurred by the Minister, the Minister may, after a reasonable period of time has passed, sell or otherwise dispose of the obstruction or keep the obstruction.
- (6) The proceeds of any sale referred to in subclause (5) are to be applied towards reducing the amount of reasonable costs and expenses incurred by the Minister. If those proceeds are more than that amount and the Minister has established who is the owner or person responsible for the obstruction to navigation, the balance remaining after that amount is deducted is to be paid to that person on application in writing by that person.

23 Obligation on operators if vessels cause an obstruction to navigation

If a vessel or any equipment associated with a vessel is a potential obstruction to navigation (within the meaning of section 16 of the Act) or danger to other vessels, the operator of the vessel must ensure that adequate warning is given to other vessel operators of the potential obstruction or danger.

Maximum penalty: 50 penalty units.

24 Obstruction of lighthouses, lightships or dolphins

A person must not, without lawful authority, be on or in or damage or interfere with any lighthouse, lightship or dolphin.

Maximum penalty: 100 penalty units.

25 Securing vessel to navigation aid or bridge

A person must not, without lawful authority, secure any vessel to any navigation aid or bridge.

Maximum penalty: 100 penalty units.

26 Restrictions near certain vessels or machinery

- (1) A person, whether or not conveyed by a vessel, must not enter or be in any navigable waters within 30 metres of any moored or anchored seagoing ship, stranded vessel, moored or anchored dredge, floating crane or machinery.
Maximum penalty: 100 penalty units.
- (2) A person, whether or not conveyed by a vessel, must not enter or be in any navigable waters within 30 metres of any sunken vessel.
Maximum penalty: 100 penalty units.
- (3) This clause does not apply to the following:
 - (a) a person or a member of a class of persons who is authorised to enter or be in the area by an officer of RMS or the Port Authority of New South Wales, the owner or master of the vessel concerned or a person in charge of the crane or machinery concerned,
 - (b) a person who is on board a vessel that is operated by a police officer, or an officer or member of staff of RMS or the Port Authority of New South Wales, acting in the exercise of his or her functions,

- (c) a person being conveyed in a vessel that is compelled by circumstances to proceed through the area concerned and that does so on a direct course without interruption,
- (d) a person who is within the distance referred to because of an emergency or in order to avoid an immediate risk of injuring persons or damaging property,
- (e) a person who is being conveyed on a vessel over which the person has no control,
- (f) a person who did not know, and could not reasonably have determined, the location of the ship, vessel, dredge, crane or machinery.

27 Restrictions near certain wharves or marine installations

- (1) A person, whether or not conveyed by a vessel, must not, without lawful authority, enter or be in any navigable waters within 100 metres of any wharf or marine installation used for the shipment, unshipment or storage of any oil, inflammable liquids, dangerous goods or explosives.

Maximum penalty: 100 penalty units.

- (2) This clause does not apply to the following:

- (a) a person or a member of a class of persons who is authorised to enter or be in the area by an officer of RMS or the Port Authority of New South Wales or a person in charge of the wharf or installation concerned,
- (b) a person who is on board a vessel that is operated by a police officer, or an officer or member of staff of RMS or the Port Authority of New South Wales, acting in the exercise of his or her functions,
- (c) a person being conveyed in a vessel that is compelled by circumstances to proceed through the area concerned and that does so on a direct course without interruption,
- (d) a person who is within the distance referred to because of an emergency or in order to avoid an immediate risk of injuring persons or damaging property,
- (e) a person who is being conveyed on a vessel over which the person has no control,
- (f) a person who did not know, and could not reasonably have determined, that the wharf or marine installation was used for the shipment, unshipment or storage of any oil, inflammable liquids, dangerous goods or explosives.

28 Restrictions near construction work

- (1) A person, whether or not conveyed by a vessel, must not, without lawful authority, enter or be in any navigable waters within 30 metres of any site:

- (a) on which construction work is being carried on by or for RMS or any other public or local authority, and
- (b) on which there is erected a sign specifying that construction work is being carried on by that agency or authority and that it is an offence to be within 30 metres of that work.

Maximum penalty: 100 penalty units.

- (2) This clause does not apply to the following:

- (a) a person or a member of a class of persons who is authorised to enter or be in the area by an officer of RMS or the public or local authority concerned,
- (b) a person who is on board a vessel that is operated by a police officer, or an officer or member of staff of RMS, acting in the exercise of his or her functions,

- (c) a person being conveyed in a vessel that is compelled by circumstances to proceed through the area concerned and that does so on a direct course without interruption,
- (d) a person who is within the distance referred to because of an emergency or in order to avoid an immediate risk of injuring persons or damaging property,
- (e) a person who is being conveyed on a vessel over which the person has no control.

29 Climbing on vessels

A person must not, without lawful authority:

- (a) climb onto or attach himself or herself to a vessel in navigable waters, or
- (b) assist any person to climb onto or attach himself or herself to any vessel in navigable waters.

Maximum penalty: 100 penalty units.

30 Restrictions near naval vessels

- (1) A person, whether or not conveyed by a vessel, must not, without lawful authority, enter or be in any navigable waters closer than:

- (a) 200 metres from the bow and 60 metres from the sides and stern of a naval vessel that is underway, or
- (b) 60 metres from a naval vessel that is moored, anchored or berthed.

Maximum penalty: 100 penalty units.

- (2) This clause does not apply to the following:

- (a) a person on board a vessel that has the consent of the master of the naval vessel concerned to be closer than the distances referred to,
- (b) a person operating a ferry providing a ferry service that is on its usual route or timetable for the day,
- (c) a person (whether or not on board a vessel) who is within the distance referred to because of an emergency or in order to avoid an immediate risk of injuring persons or causing significant damage to property,
- (d) a person who is being conveyed on a vessel over which the person has no control,
- (e) a person who did not know, and could not reasonably have determined, that the vessel was a naval vessel.

- (3) In this clause:

naval vessel means a vessel used by an arm of the Defence Force of Australia or by the naval, military or air forces of a country other than Australia.

31 Restrictions on securing vessels and interfering with safety equipment

- (1) A person must not cause a vessel that is secured to become unsecured, unless authorised to do so by:

- (a) the owner or operator of the vessel, or
- (b) a police officer, or
- (c) an officer or member of staff of RMS acting in the exercise of his or her functions.

Maximum penalty: 50 penalty units.

- (2) A person must not untie or detach any safety equipment located in the vicinity of navigable waters except for the purpose of securing the safety of any person or preventing the loss of, or damage to, any property.
Maximum penalty: 50 penalty units.

Division 6 Speed limits for certain areas

32 Application of Division where notice applies

- (1) This Division extends to the operation of a vessel in waters to which a notice under section 11 of the Act applies.
- (2) If there is an inconsistency between this Division and such a notice, this Division prevails, to the extent of the inconsistency.

33 Speed limit for Port of Sydney Central Area

- (1) This clause applies to the navigable waters between a line from the stone pillar at Bradley's Head to Hermit Point and a line from Balls Head to Ballast Point.
- (2) A person must not operate a vessel of 30 metres or more in length to which this clause applies at a speed of more than 10 knots.
Maximum penalty: 10 penalty units.
- (3) This clause does not apply to:
 - (a) ferries providing ferry services or being brought into position for the provision of those services, or
 - (b) a vessel operated by a police officer, or an officer or member of staff of RMS, acting in the exercise of his or her functions.

34 Speed limit for Port of Sydney Northern Area

- (1) This clause applies to the navigable waters between a line from Inner South Head to Inner North Head and a line from the stone pillar at Bradley's Head to Hermit Point and including Middle Harbour and North Harbour.
- (2) A person must not operate a vessel of 30 metres or more in length to which this clause applies at a speed of more than 12 knots.
Maximum penalty: 10 penalty units.
- (3) This clause does not apply to:
 - (a) ferries providing ferry services or being brought into position for the provision of those services, or
 - (b) a vessel operated by a police officer, or an officer or member of staff of RMS, acting in the exercise of his or her functions.

35 Speed limit for Port of Sydney Western Area

- (1) This clause applies to the navigable waters of the Port of Sydney including all rivers and creeks connecting with the Port west of a line from Balls Head to Ballast Point extending to Silverwater Bridge.
- (2) A person must not operate a vessel of 30 metres or more in length to which this clause applies at a speed of more than 6 knots.
Maximum penalty: 10 penalty units.
- (3) This clause does not apply to:
 - (a) ferries providing ferry services or being brought into position for the provision of those services, or

- (b) a vessel operated by a police officer, or an officer or member of staff of RMS, acting in the exercise of his or her functions.

36 Speed limit of 8 knots

- (1) This clause applies to the navigable waters of Sydney Cove within the meaning of Schedule 7.
- (2) A person must not operate a vessel in Sydney Cove at a speed of more than 8 knots. Maximum penalty: 50 penalty units.
- (3) This clause does not apply to a vessel operated by a police officer, or an officer or member of staff of RMS, acting in the exercise of his or her functions.

Division 7 Requirements relating to distances between vessels and other objects

37 Meaning of “safe distance”

For the purposes of this Division, a *safe distance* between a vessel and a person or thing (including another vessel) is a distance that will ensure that the vessel will not cause danger or injury to the person, or damage to the thing, having regard to all relevant safety factors, including weather conditions at the time, visibility, speed of the vessel and obstructions to navigation that are present.

38 Minimum distances to be maintained

- (1) The operator of any vessel (other than a parasailing vessel), including a vessel that is towing a person by any means on, over or under water must ensure that the vessel, any towing equipment and any person being towed maintain:
 - (a) a distance of not less than 60 metres from persons in or on the water and vessels (except power-driven vessels or vessels that are towing persons) or, if that is not possible, a safe distance, and
 - (b) a distance of not less than 60 metres from the location of a dive flag on the surface of the water (unless the vessel is supporting or retrieving divers or swimmers) or, if that is not possible, a safe distance and speed.Maximum penalty: 50 penalty units.
- (2) The operator of any vessel (other than a parasailing vessel) that is travelling at a speed of 6 knots or more or that is towing a person by any means on, over or under water must ensure that the vessel, any towing equipment and any person being towed maintain:
 - (a) a distance of not less than 30 metres from power-driven vessels (except vessels that are towing persons), land, structures, moored or anchored vessels and other things or, if that is not possible, a safe distance and speed, and
 - (b) a safe distance from any vessel that is towing a person.Maximum penalty: 50 penalty units.
- (3) The operator of a parasailing vessel must ensure that the vessel, any towing equipment and any person being towed maintain a distance of at least 200 metres from any other vessel and any overhead structure or apparatus erected or suspended above navigable waters. Maximum penalty: 50 penalty units.
- (4) This clause does not apply when a vessel is:
 - (a) supporting or retrieving divers from the water, or
 - (b) supporting swimmers in the water.

39 Restrictions in or near swimming areas

- (1) A person must not operate a vessel in a swimming area unless permitted to do so by a notice erected or authorised to be erected by the Minister.
Maximum penalty: 50 penalty units.
- (2) A person must not operate a power-driven vessel within 60 metres of a swimming area unless permitted to do so by a notice erected or authorised to be erected by the Minister.
Maximum penalty: 50 penalty units.
- (3) A person must not use a vessel to tow another person by any means if the other person is in, or within 60 metres of, a swimming area.
Maximum penalty: 50 penalty units.
- (4) Subclauses (1)–(3) do not apply to a vessel that is operated by a local council, Surf Life Saving New South Wales or professional lifeguards for the purpose of undertaking rescues or surf rescue training or patrolling.
- (5) For the purposes of this clause, a *swimming area* means:
 - (a) in the case of surf beaches—the area of navigable waters designated for use by swimmers by the display of surf patrol flags or signs erected by a public or local authority authorised to do so, being an area having boundaries comprising:
 - (i) the shore between the flags or signs, and
 - (ii) imaginary lines running from the flags or signs perpendicular to the shore for a distance of 500 metres from the shore (or for such shorter distance from the shore as is indicated on the flags or signs), and
 - (iii) an imaginary line running between the ends of those lines, or
 - (b) in any other case—any area of navigable waters designated for use by swimmers by the display of signs erected by a public or local authority authorised to do so, being an area having boundaries comprising:
 - (i) the shore between the signs (or, if 3 or more such signs are erected on the shore, the shore between the 2 outermost signs), and
 - (ii) imaginary lines, running from the signs, perpendicular to the shore for a distance of 60 metres from the shore (or for such shorter distance from the shore as is indicated on the signs), and
 - (iii) an imaginary line running between the ends of those lines.

40 Special provisions for vessels in the vicinity of vessels operating in chains

The operator of a vessel that is passing or crossing a vessel in chains that is underway must:

- (a) operate at a speed of 4 knots or less when within 100 metres of the chains, ropes or cables being used by the vessel in chains, and
- (b) disengage power when crossing the chains, ropes or cables being used by the vessel in chains, except when it is unsafe to do so, and
- (c) pass at a safe distance astern from the vessel in chains.

Maximum penalty: 50 penalty units.

Division 8 Towing of persons

41 Restriction on number of persons that can be towed

The operator of a vessel must not tow more than 3 persons at the same time (regardless of the number of devices used or their capacity), except in accordance with an aquatic licence.

Maximum penalty: 50 penalty units.

42 Restriction on time of day when towing can occur

The operator of a vessel must not tow any person between sunset and sunrise, except in accordance with an aquatic licence.

Maximum penalty: 50 penalty units.

43 Speed restriction where persons being towed is under 18 years

- (1) The operator of a vessel must not operate the vessel at a speed of more than 60 knots if any person under the age of 18 years is being towed by that vessel.

Maximum penalty: 50 penalty units.

- (2) This clause does not apply to a vessel operated in accordance with an aquatic licence.

44 Observer requirements

- (1) The operator of a vessel must not tow any person unless:

- (a) the operator has designated another person who is on board the vessel to act as an observer in accordance with this clause, and
- (b) the operator has explained the duties of an observer (as set out in subclause (3)) to the other person, and
- (c) the other person is qualified to act as an observer, and
- (d) the other person is not under the influence of alcohol or any other drug.

Maximum penalty: 50 penalty units.

- (2) For the purposes of subclause (1) (c), a person is qualified to act as an observer if that person:

- (a) has attained the age of 16 years, or
- (b) is the holder of a boat driving licence or a personal watercraft driving licence.

- (3) An observer has the following duties:

- (a) to face and watch the person being towed,
- (b) to report to the operator of the vessel all matters affecting the safety of the person being towed and the safety of any other person affected by the towing operation.

Maximum penalty: 50 penalty units.

- (4) Subclause (1) does not apply to a personal watercraft in any of the following circumstances:

- (a) while the personal watercraft is operated by Surf Life Saving New South Wales or professional lifeguards for the purpose of undertaking rescues or surf rescue training,
- (b) while the personal watercraft is being operated in open waters for tow-in surfing and there are no surfboard riders present, so long as the conditions set out in subclause (5) are being complied with.

- (5) For the purposes of subclause (4) (b), the following conditions must be complied with:
- (a) the personal watercraft must be equipped with:
 - (i) a quick release floating tow rope with a minimum length of 7 metres, and
 - (ii) a two-way communication device, and
 - (iii) a rescue sled, and
 - (iv) a second kill switch lanyard wrapped around the handlebars, and
 - (v) a toolkit, and
 - (vi) a bow tow-line with a minimum length of 7 metres,
 - (b) the operator of the vessel:
 - (i) must hold a current first aid certificate, and
 - (ii) must have passed a course or examination approved by RMS for the purposes of this paragraph, and
 - (iii) must carry dive fins and a safety knife on his or her person, and
 - (iv) must give right of way to all other boating and recreational activities, and
 - (v) must remain at least 200 metres from all other vessels and persons in the water, and
 - (vi) must not tow more than one person at a time,
 - (c) in a case where the personal watercraft is being operated for tow-in surfing, the surfboard rider:
 - (i) must hold a current personal watercraft driving licence, and
 - (ii) must hold a current first aid certificate, and
 - (iii) must wear an appropriate lifejacket, and
 - (iv) must have passed a course or examination approved by RMS for the purposes of this paragraph.

45 Responsibilities in relation to trailing equipment

The operator of a vessel must ensure that any rope, object or other apparatus trailing from the vessel does not cause any obstruction to navigation, danger to any person or damage to any property.

Maximum penalty: 50 penalty units.

46 Tow rope and towing device requirements

- (1) The operator of a power-driven vessel must ensure that the tow rope or towing device used to tow a person ensures that the person being towed is not less than 7 metres behind the vessel.
Maximum penalty: 50 penalty units.
- (2) This clause does not apply if:
- (a) the tow rope or towing device used to tow a person is a training bar, and
 - (b) the person, while being towed, is:
 - (i) learning how to barefoot ski or use a water ski or similar device, and
 - (ii) at least one metre from the side of the vessel, and
 - (iii) at least one metre forward of the vessel's exhaust port.
- (3) In this clause:
training bar means a metal bar or pole that:

- (a) is fitted to a vessel and extends perpendicular to the centreline of the vessel, and
- (b) can be held directly or by means of a short rope by a person being towed.

Division 9 Personal watercraft

47 Personal watercraft behaviour label

- (1) The owner of a personal watercraft must ensure that the personal watercraft is not operated by any person unless it has a label (a *behaviour label*) firmly affixed to it that:
 - (a) contains a description of requirements to carry a personal watercraft licence, wear a lifejacket, maintain minimum distances and comply with exclusion zones imposed by the Act and this Regulation, and
 - (b) is issued by RMS, and
 - (c) is not in any way defaced, obliterated or concealed, and
 - (d) is clearly visible from the steering position at all times.Maximum penalty: 20 penalty units.
- (2) This clause does not apply to a personal watercraft that is registered under the law of another State or Territory or of another country.

48 Personal watercraft excluded from Sydney Harbour and its tributaries

- (1) The operator of a personal watercraft must not operate the personal watercraft on any navigable waters in a personal watercraft exclusion zone.
Maximum penalty: 50 penalty units.
- (2) The owner of a personal watercraft must not permit a person to operate the personal watercraft on any navigable waters in a personal watercraft exclusion zone.
Maximum penalty: 50 penalty units.
- (3) Subclauses (1) and (2) do not apply to a police officer, or an officer or member of staff of RMS, acting in the exercise of his or her functions.
- (4) A person who commits an offence under subclause (1) may be disqualified by the responsible licensing official from holding or obtaining a boat driving licence:
 - (a) for the first such offence—for a period of up to 1 year after the commission of the offence, or
 - (b) for the second or subsequent such offence—for a period of up to 2 years after the commission of the offence.The disqualification is in addition to any penalty imposed for the offence.
- (5) Subject to subclause (6), the responsible licensing official may at any time remove, or reduce the period of, a disqualification imposed by subclause (4).
- (6) A disqualification imposed by subclause (4) does not operate to the extent to which it is inconsistent with any order of a court, or any decision of the responsible licensing official under section 38 of the Act, that disqualifies the person concerned from holding or obtaining a licence.
- (7) For the purposes of subclause (4), a person is taken to have committed an offence:
 - (a) at the time that the person is found guilty of the offence by a court, or
 - (b) at the time that the person pays the penalty required by a penalty notice served on the person under section 126 of the Act in respect of the alleged offence (or if the person does not pay the penalty and does not elect to have the matter

dealt with by a court, at the time that enforcement action is taken against the person under Division 3 or 4 of Part 4 of the *Fines Act 1996*).

- (8) Subclause (4) (b) extends to a person whose first offence against a provision that corresponded with subclause (1) was committed before the commencement of this clause.

- (9) In this clause:

personal watercraft includes a propeller-driven vessel that is designed to be operated by a person standing, sitting astride or kneeling on the vessel.

personal watercraft exclusion zone means the waters of Port Jackson, and includes the waters of all tidal bays, rivers and their tributaries connected or leading to Sydney Harbour bounded by high water mark and lying to the west of a line commencing at the southernmost point of North Head and running to the northernmost point of South Head.

49 Operation of personal watercraft at any speed

- (1) A person must not operate a personal watercraft in an irregular manner on any navigable waters in the personal watercraft restriction zone that are within 200 metres of a river bank or shore.

Maximum penalty: 50 penalty units.

- (2) A person must not operate a personal watercraft in an irregular manner on any navigable waters outside the personal watercraft restriction zone that are within 200 metres of a river bank or shore, if one or more dwellings are:

- (a) located on land within 200 metres of the river bank or shore adjacent to the waters, and
(b) visible from those waters.

Maximum penalty: 50 penalty units.

- (3) This clause does not apply to any of the following:

- (a) the operator of a personal watercraft that is towing a person,
(b) a police officer, or an officer or member of staff of RMS, acting in the exercise of his or her functions.

- (4) In this clause:

operating a personal watercraft in an irregular manner means:

- (a) driving it in a circle or other pattern, or
(b) weaving or diverting, or
(c) surfing down, or jumping over or across, any swell, wave or wash,

but does not include making any necessary jump, turn or diversion.

personal watercraft restriction zone means the waters (including any tributaries) of Avoca Lake, Botany Bay, Brisbane Water, Broken Bay, Bulbararing Lagoon, Cockrone Lagoon, Cooks River, Dee Why Lagoon, Georges River, Hawkesbury River, Manly Lagoon, Manly Reservoir, Narrabeen Lakes, Nepean River, Port Hacking, Prospect Reservoir, Terrigal Lagoon, Wamberal Lagoon and Woronora River (but does not include any open waters).

50 Operation of personal watercraft between sunset and sunrise

- (1) A person must not operate a personal watercraft between sunset and sunrise, except in accordance with an aquatic licence.

Maximum penalty: 50 penalty units.

- (2) The owner of a personal watercraft must not permit a person to operate the personal watercraft between sunset and sunrise unless the watercraft is operated in accordance with an aquatic licence.
Maximum penalty: 50 penalty units.
- (3) This clause does not apply to a police officer, or an officer or member of staff of RMS, acting in the exercise of his or her functions.

Division 10 Safe loading of vessels

51 Maximum safe loading level of certain vessels

- (1) The owner of a vessel must ensure that a label (a *safety label*) that complies with this clause is affixed to the vessel in accordance with this clause.
Maximum penalty: 50 penalty units.
- (2) The safety label must be in a form approved by RMS.
- (3) The safety label must show the maximum safe load (comprising the total weight of persons and equipment) that the vessel may carry in calm water, or the maximum number of persons the vessel may carry in calm water, and such other safety information as determined by RMS.
- (4) The information to be displayed on the safety label relating to the maximum safe load and maximum number of persons that the vessel may carry must be calculated in accordance with:
 - (a) Australian Standard AS 1799.1—2009, *Small craft—General requirements for power boats* as in force from time to time, or
 - (b) a standard approved in writing by RMS, or
 - (c) the ABP Standard (within the meaning of Part 4).
- (5) The safety label must be firmly affixed to the vessel:
 - (a) in a position that is clearly visible from each steering position on the vessel and complies with any instructions on the label relating to positioning, or
 - (b) in such other position as is approved in writing by RMS.
- (6) The safety label must not be defaced, obliterated or concealed.
- (7) The owner and operator of a vessel must ensure that:
 - (a) the vessel is not loaded with persons or equipment (or both), the total weight of which exceeds the maximum safe load as calculated in accordance with subclause (4), and
 - (b) the number of persons on the vessel does not exceed the maximum number of persons the vessel may carry, as calculated in accordance with subclause (4).Maximum penalty: 50 penalty units.
- (8) In calculating the number of persons on board a vessel for the purposes of this clause, children under the age of one year are to be disregarded.
- (9) This clause does not apply to the following vessels:
 - (a) a personal watercraft,
 - (b) a vessel propelled by oars or paddles and that does not have an engine,
 - (c) a vessel used solely for the purpose of racing or competition,
 - (d) a sailing vessel with or without an engine,
 - (e) a commercial vessel,

- (f) a vessel regulated under the *Navigation Act 2012* of the Commonwealth or as a regulated Australian vessel,
- (g) a vessel that has been in State waters for less than 3 months and:
 - (i) that is not ordinarily operated in State waters, and
 - (ii) that is registered under the law of another State or Territory or of another country, and
 - (iii) that is operated in accordance with the requirements (if any) of the law of that State, Territory or country relating to the maximum safe loading level of vessels, the labelling of vessels in relation to maximum safe loads and the maximum number of persons that the vessel may carry.

52 Maximum safe loading levels for personal watercraft

The owner and operator of a personal watercraft must ensure that the number of persons on the vessel does not exceed the maximum number of persons the vessel may carry specified by the manufacturer of the vessel.

Maximum penalty: 50 penalty units.

Part 3 Special safety requirements for certain waters and vessels

Division 1 Waterway management

53 Operation of commercial vessels in State waters

- (1) RMS may issue a direction in relation to waterway management matters to:
 - (a) a person operating a commercial vessel, or
 - (b) a person or persons operating a commercial vessel of a class referred to in the direction, or
 - (c) a person or persons operating a commercial vessel carrying out a function or activity referred to in the direction.
- (2) A direction may be issued by notice in writing given to the person concerned or by publication in the Gazette.
- (3) If a direction is published in the Gazette, the direction takes effect at the beginning of the day after it is published, or on any later date specified in the direction.
- (4) A person operating a vessel in State waters must comply with any such direction.
Maximum penalty: 50 penalty units.
- (5) For the purposes of this clause, *waterway management matter* includes, but is not limited to, the following:
 - (a) the designation of areas in which particular vessels may operate, or be prohibited from operating,
 - (b) the designation of areas in which vessels may be used for particular purposes or where the use of vessels for particular purposes may be prohibited,
 - (c) the imposition of speed restrictions,
 - (d) the imposition of navigation requirements.

Division 2 Navigation requirements for commercial adventure vessels

54 Definitions

In this Division, *commercial adventure vessel* means a Class 1 or Class 2 commercial vessel used for the purposes of providing high speed adventure or thrill rides for passengers.

55 Speed requirements for commercial adventure vessels in Port Jackson waters

- (1) The master of a commercial adventure vessel must not operate the vessel in Port Jackson at a speed exceeding:
 - (a) 20 knots in the waters west of a straight line drawn between the starboard lateral marker at Bradley's Head and Woollahra Point, or
 - (b) 30 knots in the waters east of that line.Maximum penalty: 50 penalty units.
- (2) This clause does not apply to the following waters:
 - (a) Sydney Cove,
 - (b) any of the waters of Port Jackson for which a notice is displayed in accordance with section 11 of the Act that imposes restrictions on the speed of vessels in those waters.

Note. Clauses 33 and 36 contain provisions relating to speed limits for Sydney Cove.

56 Navigation requirements for commercial adventure vessels operating in irregular manner

- (1) The master of a commercial adventure vessel must ensure that, when operating the vessel in an irregular manner, the vessel maintains:
- (a) a distance of not less than 200 metres from any person in the water, and
 - (b) a distance of not less than 200 metres from any other vessel, and
 - (c) a distance of not less than 100 metres from any fixed object, and
 - (d) when coming to an abrupt stop, a distance of at least 500 metres in front of any ferry that is underway on the same path.

Maximum penalty: 50 penalty units.

- (2) In this clause:

operating a vessel in an irregular manner means:

- (a) driving it in a circle or other pattern, or
- (b) weaving or diverting, or
- (c) surfing down, or jumping over or across, any swell, wave or wash, but does not include making any necessary jump, turn or diversion.

Division 3 Requirements for navigation in the vicinity of Lord Howe Island

57 Navigation requirements for certain vessels

- (1) The owner and master of a Class 1 or Class 2 commercial vessel are each guilty of an offence if the vessel departs Lord Howe Island and is operated in open waters:
- (a) between sunset and sunrise, or
 - (b) when the wind speed exceeds 25 knots, or
 - (c) when the wind is in the segment 150 degrees to 320 degrees and the wind speed exceeds 21 knots.

Maximum penalty: 50 penalty units.

- (2) The owner and master of a Class 1 or Class 2 commercial vessel are each guilty of an offence if the vessel is operated in waters within Lord Howe Island Lagoon between sunset and sunrise and for the whole period during which the vessel is operated:

- (a) the wind speed exceeds 15 knots, or
- (b) tidal conditions do not exceed 300 millimetres from the low water mark.

Maximum penalty: 50 penalty units.

Division 4 Requirements for navigation in Sydney Cove

58 Requirements for master of vessel operating in Sydney Cove

The master of a vessel must ensure that the requirements of Schedule 7 are complied with in relation to the vessel.

Maximum penalty: 50 penalty units.

Part 4 Requirements relating to builders plates for certain recreational vessels

Division 1 Preliminary

59 Definitions

In this Part:

ABP Standard means the standard entitled *National Standard for the Australian Builders Plate for Recreational Boats*, published under the authority of the Ministers comprising the former Australian Transport Council, and as in force from time to time.

builders plate means a plate fixed to a vessel displaying information about the vessel.
owner builder of a vessel means a natural person who builds the vessel for the person's own use.

second hand vessel means a vessel that has been used otherwise than as follows:

- (a) in the course of being built or tested,
- (b) by the builder only,
- (c) for the purpose of transporting it for the purpose of sale,
- (d) for the purpose of demonstrating it to a purchaser.

sell includes:

- (a) supply for sale, or
- (b) supply in furtherance of a trade or business, or
- (c) offer or display for sale.

60 Application of Part

- (1) This Part applies to all vessels except the following vessels:
 - (a) a second hand vessel,
 - (b) an amphibious vehicle, being a vessel that is also a motor vehicle and that is required to be registered within the meaning of the *Road Transport Act 2013*,
 - (c) a canoe, kayak or surf ski or similar vessel designed to be powered by paddle,
 - (d) a pedal powered boat,
 - (e) a personal watercraft that complies with subclause (3),
 - (f) a rowing shell used for racing or rowing training,
 - (g) a sailboard or kiteboard or other similar vessel,
 - (h) a surf row boat,
 - (i) a hydrofoil or hovercraft,
 - (j) a sailing vessel, being a vessel that has sail as the primary means of propulsion, with or without an auxiliary means of mechanical propulsion,
 - (k) a submersible, being a powered vessel capable of submerging or operating underwater such as a submarine,
 - (l) an aquatic toy, being an object designed primarily for play in or on water, for example:
 - (i) an object designed solely to be towed behind a recreational vessel, and
 - (ii) an inflatable boat to which ISO 6185 *Inflatable boats*, as in force from time to time, does not apply,

public consultation draft

Marine Safety Regulation 2015 [NSW]
Part 4 Requirements relating to builders plates for certain recreational vessels

- (m) an inflatable boat to which ISO 6185 *Inflatable boats*, as in force from time to time, applies and which complies with subclause (5),
 - (n) a commercial vessel or a regulated Australian vessel or vessel regulated under the *Navigation Act 2012* of the Commonwealth,
 - (o) a vessel used only for the purpose of racing in organised events.
- (2) This Part does not apply to a vessel that, before 1 July 2006, had reached a stage of construction of having the keel laid or a stage of construction at which:
- (a) the vessel was identifiable as a vessel of a particular type, and
 - (b) a part of the vessel had been fabricated and assembled that had a mass of at least 50 tonnes or one per cent of the mass of all structural material of the proposed completed vessel, whichever is the lesser.
- (3) This Part does not apply to a vessel that is a personal watercraft if:
- (a) the following information is written on or attached to the vessel in a clearly visible place:
 - (i) the total weight of persons and equipment that the vessel may carry in calm water (expressed in kilograms), as recommended by the builder of the vessel,
 - (ii) the maximum number of persons the vessel may carry, as recommended by the builder of the vessel, or
 - (b) the vessel is designed to carry not more than 2 persons.
- (4) In calculating the number of persons on board a vessel for the purposes of subclause (3) (b), children under the age of one year are to be disregarded.
- (5) This Part does not apply to a vessel that is an inflatable boat referred to in subclause (1) (m) if the vessel:
- (a) has a plate attached to it in accordance with *European Directive 94/25/EC—Recreational Craft Directive*, as in force from time to time, that certifies that the vessel complies with the requirements of that Directive, or
 - (b) has a plate attached to it in accordance with the requirements of the US National Marine Manufacturers Association set out in the *NMMA Certification Handbook*, as in force from time to time, that certifies that the vessel complies with the requirements of that Handbook.

61 Variation of ABP Standard

For the purposes of this Part, a requirement of the ABP Standard to the effect that information on a builders plate for a vessel must include the name of the builder of the vessel is to be read as a requirement that the information must include the name of the person authorised to approve information who approves the information and the capacity in which the person approves the information.

Division 2 Requirements relating to builders plates

62 Vessel for sale required to have builders plate

A person must not sell a vessel to which this Part applies unless:

- (a) a builders plate is fixed to the vessel in accordance with the ABP Standard, and
- (b) the plate contains the information required by the ABP Standard, and
- (c) the information on the plate is correct at the time of the sale, and
- (d) the plate has been fixed to the vessel in accordance with the requirements of the ABP Standard.

Maximum penalty: 50 penalty units.

63 Builders plate exemptions—available defences

(1) Owner builder

It is a defence to a prosecution for an offence against clause 62 if the defendant establishes that the defendant was an owner builder of the vessel concerned and the vessel was sold more than 5 years after it was first used or first registered.

(2) Plate already fixed

It is a defence to a prosecution for an offence against clause 62 if the defendant establishes that:

- (a) the defendant was not the builder of the vessel, and
- (b) there was a plate fixed to the vessel when it was sold by the defendant and the defendant reasonably believed that the plate was a builders plate for the vessel, and
- (c) the defendant had no reason to believe that the information on the plate was incorrect, and
- (d) the defendant was not aware of any modification of the vessel that would affect the accuracy of the information on the plate.

(3) Vessels for export

It is a defence to a prosecution for an offence against clause 62 if the defendant establishes that the vessel was to be exported overseas.

64 Persons authorised to approve information on builders plates

For the purposes of this Part, the information on a builders plate fixed to or to be fixed to a vessel may only be approved by any of the following persons (a *person authorised to approve information*):

- (a) the builder of the vessel so long as the builder of the vessel is not an owner builder,
- (b) a person who is approved by RMS for the purposes of this clause,
- (c) a person who imported the vessel into Australia from overseas,
- (d) a person authorised to do so under a corresponding law of another Australian jurisdiction.

65 Offences relating to fixing of builders plates on vessels

- (1) This clause applies to a vessel that is required to have a builders plate fixed to it under this Part when sold in New South Wales.
- (2) A person must not fix a builders plate to a vessel to which this clause applies if:
 - (a) the person has reason to believe that the information on the builders plate is incorrect or does not comply with the ABP Standard, or
 - (b) the information on the plate has not been approved by a person authorised to approve information.

Maximum penalty: 50 penalty units.

- (3) A person must not alter the information on a builders plate that is fixed to a vessel to which this clause applies if:
 - (a) the person has reason to believe that the information will be incorrect if so altered or will not comply with the ABP Standard, or

- (b) the information as so altered has not been approved by a person authorised to approve information.

Maximum penalty: 50 penalty units.

66 Offence relating to approval of information on builders plates

A person must not approve any information on a builders plate fixed to, or to be fixed to, a vessel that is required to have a builders plate fixed to it under this Part when sold in New South Wales unless:

- (a) the person is a person authorised to approve information, and
- (b) the information is correct and complies with the ABP Standard.

Maximum penalty: 50 penalty units.

67 Builders plate not to be altered unless authorised

A person must not alter, deface, conceal, remove or obliterate a builders plate that is fixed to a vessel in accordance with this Part unless the person is, or is authorised to do so by, a person authorised to approve information.

Maximum penalty: 50 penalty units.

68 Vessel may not be registered without builders plate

RMS may refuse to register for the first time a vessel to which a builders plate is required to be fixed under this Part when sold in New South Wales if:

- (a) a builders plate is not fixed to the vessel in accordance with the ABP Standard, or
- (b) RMS has reason to believe the information on a builders plate fixed to the vessel is incorrect.

Part 5 Marine safety licences

Division 1 General provisions

69 Definition

In this Part:

marine pilotage code means the NSW Marine Pilotage Code as in force from time to time and published by the Minister on the website of Transport for NSW.

Note. The website of Transport for NSW is www.transport.nsw.gov.au.

70 Declaration of certain marine safety licences

For the purposes of all of the provisions of the Act, the following licences are declared to be marine safety licences under section 29 (h) of the Act:

- (a) an aquatic licence,
- (b) a bar crossing licence.

71 Applications for marine safety licences

- (1) An application for a marine safety licence must:
 - (a) be made to the responsible licensing official in the form approved by the responsible licensing official, and
 - (b) be accompanied by the particulars and documents required by the responsible licensing official (including, for example, medical assessments), and
 - (c) be accompanied by such proof of identity documentation as is required by the responsible licensing official, and
 - (d) be accompanied by the relevant fee, and
 - (e) comply with any other requirements of this Part in relation to applications for the type of marine safety licence concerned.
- (2) A reference in this Division to an application for a marine safety licence includes a reference to an application for a further marine safety licence whether or not made before or after the expiry of the previous licence.
- (3) The responsible licensing official may waive any of the requirements of this Regulation in relation to an application for a further marine safety licence.

72 Eligibility for licence

- (1) The following marine safety licences may be granted only to a single natural person:
 - (a) a boat driving licence,
 - (b) a marine pilot's licence,
 - (c) a marine pilotage exemption certificate,
 - (d) a certificate of local knowledge,
 - (e) a bar crossing licence.
- (2) The following marine safety licence may be granted only to a single natural person or a single other legal entity:
 - (a) a vessel registration certificate,
 - (b) an aquatic licence.

73 Refusal to issue marine safety licence

- (1) An application for a marine safety licence may be refused in any of the following circumstances:
 - (a) if any information provided by the applicant is found to be false or misleading in a material particular or is, in the opinion of the responsible licensing official, inadequate to enable the application to be assessed properly,
 - (b) if the applicant is not, in the opinion of the responsible licensing official, a fit and proper person to hold the licence,
 - (c) if the applicant has been issued with a penalty notice in relation to an offence against the marine legislation and that penalty notice has not been withdrawn or a court has not dismissed the relevant charges,
 - (d) if the applicant has been found guilty of an offence against the marine legislation,
 - (e) in the case of an application for a further licence, if the applicant has failed to comply with any condition of a current or previous licence,
 - (f) in the case of an application for a further licence, if any fees for, or in connection with, a current or previous licence are overdue and have been overdue for a period of at least 14 days,
 - (g) if the responsible licensing official determines that it is in the public interest to do so,
 - (h) if the applicant is not eligible for the licence under this Regulation.
- (2) In addition to the circumstances in which the responsible licensing official may refuse to issue a licence under subclause (1), the responsible licensing official may refuse to issue a vessel registration certificate if:
 - (a) the holder of the certificate fails to comply with any of the requirements of Division 2 in relation to the vessel, or
 - (b) the vessel is an unsafe vessel (within the meaning of section 44 of the Act), or
 - (c) the responsible licensing official is of the opinion that the vessel may cause damage to any property or the environment, or
 - (d) the holder of the certificate ceases to own the vessel.
- (3) In addition to the circumstances in which the responsible licensing official may refuse to issue a licence under subclause (1), the responsible licensing official may refuse to issue a boat driving licence if the applicant for the licence is, in the opinion of the responsible licensing official, incapable of safely operating a vessel of the type to which the licence relates, or is physically or medically unfit to operate such a vessel.
- (4) If the responsible licensing official refuses to issue a marine safety licence, the responsible licensing official is to give notice in writing of the decision, and the reasons for the decision, to the applicant concerned.

74 When immediate boat driving licence suspension notice may be issued

- (1) An *immediate licence suspension notice* is a notice in a form approved by RMS that informs the holder of a boat driving licence of the fact that:
 - (a) the licence is suspended, and
 - (b) if the holder is dissatisfied with the suspension of the notice, the holder may apply to the Tribunal for an administrative review under the *Administrative Decisions Review Act 1997*.

public consultation draft

Marine Safety Regulation 2015 [NSW]
Part 5 Marine safety licences

- (2) An authorised officer may give the holder of a boat driving licence an immediate licence suspension notice in any of the following circumstances:
 - (a) if the holder of the boat driving licence is charged by a police officer (whether or not the same police officer) with an offence involving the death of, or grievous bodily harm to, another person caused by the use of a vessel, being an offence that comprises:
 - (i) the crime of murder or manslaughter, or
 - (ii) an offence against section 33, 35 (2), 52A or 54 of the *Crimes Act 1900*,
 - (b) the holder of the boat driving licence is given a penalty notice for, or is charged with, an offence under section 13 of the Act,
 - (c) the holder of the boat driving licence is given a penalty notice for, or is charged with, an offence under section 24 of the Act that involves a middle range prescribed concentration of alcohol or high range prescribed concentration of alcohol.
- (3) An immediate licence suspension notice may be given to the holder of a boat driving licence at any time within 48 hours after:
 - (a) the holder being served with a penalty notice for the offence concerned, or
 - (b) the holder being charged with the offence concerned.
- (4) An immediate licence suspension notice operates to suspend the licence from a date specified in the notice, or (if the notice so specifies) immediately on receipt of the notice, until:
 - (a) the charge is heard and determined by a court (that is, when the offence is proved or the court attendance notice is dismissed), or
 - (b) until the charge is withdrawn (that is, when the person charged is notified in writing of that fact by the responsible licensing official or when it is withdrawn before the court), or
 - (c) a decision is made not to take or continue proceedings against a person (that is, when the person is notified in writing of that fact by a responsible licensing official or the proceedings are discharged by the court), or
 - (d) a decision is made not to enforce a penalty notice in relation to a person (that is, when the person is notified in writing of that fact by:
 - (i) the responsible licensing official, or
 - (ii) an appropriate officer for the penalty notice within the meaning of Part 3 of the *Fines Act 1996*, or
 - (iii) the Commissioner of Fines Administration.
- (5) Particulars of each immediate licence suspension notice given under this clause are to be forwarded to RMS immediately after the notice is given.
- (6) If an immediate licence suspension notice is given to the holder of a boat driving licence, any boat driving licence held by the person is suspended in accordance with the terms of the notice.
- (7) A person who holds a boat driving licence and who is given an immediate licence suspension notice must surrender the person's licence.
Maximum penalty: 20 penalty units.
- (8) For the purposes of this clause, a person is charged with an offence when particulars of the offence are notified in writing to the person by a responsible licensing official.

75 Suspension or cancellation of marine safety licence

- (1) For the purposes of section 38 (1) (c) of the Act, the prescribed circumstances in which the responsible licensing official may suspend or cancel a marine safety licence are as follows:
 - (a) any information provided by the holder of the licence for the purposes of the marine legislation is found to be false, misleading or inadequate in a material particular,
 - (b) the holder of the licence is not, in the opinion of the responsible licensing official, a fit and proper person to hold the licence,
 - (c) the holder of the licence has failed to comply with any condition of the licence,
 - (d) the holder of the licence has committed an offence against any provision of the marine legislation or section 52B of the *Crimes Act 1900* or any provision of the law of the Commonwealth or of another State or a Territory that the responsible licensing official considers is similar to a provision of the marine legislation or that section,
 - (e) if the responsible licensing official determines that it is in the public interest to do so,
 - (f) the holder of the licence requests that the licence be suspended or cancelled.
- (2) In addition to the circumstances in which the responsible licensing official may suspend or cancel a licence under subclause (1), the responsible licensing official may suspend or cancel a vessel registration certificate if:
 - (a) the holder of the certificate fails to comply with any of the requirements of Division 2 or of the responsible licensing official in relation to the vessel, or
 - (b) the vessel is an unsafe vessel (within the meaning of section 44 of the Act), or
 - (c) the responsible licensing official is of the opinion that the vessel may cause damage to any property or the environment, or
 - (d) the holder of the certificate ceases to own the vessel.
- (3) In addition to the circumstances in which the responsible licensing official may suspend or cancel a licence under subclause (1), the responsible licensing official may suspend or cancel a boat driving licence if:
 - (a) the holder of the licence is, in the opinion of the responsible licensing official, incapable of safely operating a vessel of the type to which the licence relates or is physically or medically unfit to operate such a vessel, or
 - (b) the holder of the licence fails to provide any medical or eyesight assessment or report required by the responsible licensing official, or
 - (c) the holder of the licence fails to undertake any further courses or seminars required by the responsible licensing official, or
 - (d) the holder has had a similar licence or authorisation suspended or cancelled under the laws of the Commonwealth or another State or a Territory for disciplinary reasons.
- (4) In addition to the circumstances in which the responsible licensing official may suspend or cancel a licence under subclause (1), the responsible licensing official may suspend or cancel a marine pilot's licence, a marine pilotage exemption certificate or a certificate of local knowledge if:
 - (a) the holder of the licence or certificate is, in the opinion of the responsible licensing official, incapable of safely operating a vessel of the type to which the licence or certificate relates or is physically or medically unfit to operate such a vessel, or

- (b) the holder of the licence or certificate fails to provide any medical or eyesight assessment or report required by the responsible licensing official, or
 - (c) the holder of the licence or certificate has failed to satisfactorily complete any further courses or training required by the responsible licensing official, or
 - (d) the holder has had a similar licence or certificate suspended or cancelled under the laws of the Commonwealth or another State or a Territory for disciplinary reasons, or
 - (e) the holder of the licence or certificate ceases to hold a relevant qualification, within the meaning of clause 105 (2).
- (5) If the responsible licensing official suspends or cancels a marine safety licence under this clause or clause 74, the responsible licensing official is to give notice in writing of the decision and (except in the case where the holder of the licence has requested the suspension or cancellation) the reasons for the decision to the holder of the licence.
- (6) The suspension or cancellation of a marine safety licence by the responsible licensing official (except in accordance with section 111 of the Act or under clause 74) takes effect on the day on which notice of it is given as referred to in subclause (5) or on a later day specified in the notice.
- (7) For the purposes of subclause (1) (d), a person is taken to have committed an offence at the time that the person:
- (a) is found guilty of the offence by a court, or
 - (b) pays the penalty required by a penalty notice served on the person under section 126 of the Act in respect of the alleged offence (or if the person does not pay the penalty and does not elect to have the matter dealt with by a court, at the time that enforcement action is taken against the person under Division 3 or 4 of Part 4 of the *Fines Act 1996*).

76 Disqualification of person from holding or obtaining marine safety licence

- (1) The responsible licensing official may disqualify a person from holding or obtaining a marine safety licence for a specified period (not exceeding 2 years) if the person has committed an offence against the marine legislation.
- (2) For the purposes of this clause, a person is taken to have committed an offence at the time that the person:
- (a) is found guilty of the offence by a court, or
 - (b) pays the penalty required by a penalty notice served on the person under section 126 of the Act in respect of the alleged offence (or if the person does not pay the penalty and does not elect to have the matter dealt with by a court, at the time that enforcement action is taken against the person under Division 3 or 4 of Part 4 of the *Fines Act 1996*).

77 Change of particulars to a marine safety licence

The holder of a marine safety licence must notify the responsible licensing official in writing, or in another manner acceptable to the responsible licensing official, of each of the following events within 14 days of the event occurring:

- (a) any change in the licence holder's particulars recorded on the licence, including any change of name or address,
- (b) any change in the vessel particulars recorded on the licence, including any change in the vessel name, proposed use of the vessel or proposed area of operation,

- (c) any change in the vessel's ownership or control, including the date of any such change and the name or address of the person to whom ownership or control has passed,
- (d) any advice received from a medical practitioner that casts doubt on the person's fitness to hold the marine safety licence.

Maximum penalty: 20 penalty units.

78 Issue of replacement marine safety licence

- (1) If a marine safety licence is lost, stolen, damaged, destroyed or defaced, the holder of the licence must, within 14 days, inform the responsible licensing official in writing.

Maximum penalty: 20 penalty units.

- (2) The responsible licensing official may, on payment of the relevant fee, issue a replacement marine safety licence to a person if satisfied that the person is the holder of a licence that has been lost, stolen, damaged, destroyed or defaced.

79 Renewal of marine safety licence

- (1) The responsible licensing official may send a notice of renewal to the holder of a marine safety licence.

- (2) A notice of renewal is a notice:

- (a) addressed to a holder of a marine safety licence, and
- (b) stating that, if the marine safety licence is not renewed on or before a specified date, the marine safety licence will expire.

- (3) If the responsible licensing official fails to send a notice of renewal, that failure does not affect:

- (a) the expiry of the marine safety licence, or
- (b) the obligation of a holder of a marine safety licence to renew the licence if a licence is required by or under the Act.

80 Return of a marine safety licence

- (1) The responsible licensing official may request in writing the holder of a marine safety licence to return the licence and documentation for a vessel to the responsible licensing official:

- (a) to enable amendment of any conditions associated with the licence, or endorsement of conditions on or in association with the licence, or
- (b) for the purpose of issuing a different licence, or
- (c) if the licence contains a photograph of the holder of the licence and the responsible licensing official considers that the photograph is no longer a true likeness of the holder, to enable a new photograph to be taken.

- (2) The holder of a marine safety licence to whom a request is made under this clause must not, without reasonable excuse, fail to comply with the request within the time specified in the request.

Maximum penalty: 20 penalty units.

81 Cheating or forgery

- (1) An applicant for a marine safety licence must not cheat in any examination associated with the marine safety licence.

Maximum penalty: 10 penalty units.

- (2) A person must not:
- (a) forge a marine safety licence, or
 - (b) alter a marine safety licence without proper authorisation, or
 - (c) use a forged marine safety licence, or
 - (d) use a marine safety licence that has been altered without proper authorisation.
- Maximum penalty: 10 penalty units.
- (3) A person who commits an offence under subclause (1) or (2) is disqualified from holding or obtaining any licence under this Part for a period of 12 months after the commission of the offence. The disqualification is in addition to any penalty imposed for the offence.
- (4) A disqualification imposed by subclause (3) does not operate to the extent to which it is inconsistent with any order of a court, or any decision of the responsible licensing official under section 38 of the Act, that disqualifies the person concerned from holding or obtaining a licence.
- (5) For the purposes of this clause, a person is taken to have committed an offence at the time that the person:
- (a) is found guilty of the offence by a court, or
 - (b) pays the penalty required by a penalty notice served on the person under section 126 of the Act in respect of the alleged offence (or if the person does not pay the penalty and does not elect to have the matter dealt with by a court, at the time that enforcement action is taken against the person under Division 3 or 4 of Part 4 of the *Fines Act 1996*).

Division 2 Vessel registration

82 Vessels exempt from registration

- (1) For the purposes of section 50 (3) of the Act, the following classes of vessel are exempt from registration:
- (a) vessels that:
 - (i) are less than 5.5 metres in length, and
 - (ii) are not power-driven vessels or are fitted with an engine having a power rating of less than 4.0 kilowatts, and
 - (iii) are not the subject of an occupation licence under the *Management of Waters and Waterside Lands Regulations—N.S.W.* or wet berthed at a marina or moored or berthed in accordance with a lease granted by RMS, and
 - (iv) are not occupying any navigable waters by direction of, or with the permission of, the Crown or any person or body lawfully entitled to give such a direction or permission,
 - (b) off-the-beach vessels that:
 - (i) are not the subject of an occupation licence under the *Management of Waters and Waterside Lands Regulations—N.S.W.* or wet berthed at a marina, and
 - (ii) are not occupying any navigable waters by direction of, or with the permission of, the Crown or any person or body lawfully entitled to give such a direction or permission,
 - (c) any canoe, kayak, surf ski or rowing shell of any length,
 - (d) seaplanes,

- (e) a vessel that is in the charge of a trader and is being used for purposes connected with the manufacture, alteration, repair, testing, sale or demonstration of:
 - (i) a commercial purpose of the vessel, or
 - (ii) an engine or component that forms part of or is used in, or is intended to form part of or to be used in, a vessel.
- (2) For the purposes of section 50 (3) of the Act, a vessel owned by the State Emergency Service or Surf Life Saving New South Wales is exempt from registration if:
 - (a) the vessel clearly displays a unique identification number for that body on each side of the forward half of the vessel in block letters of at least 150 millimetres in height or, in the case of a personal watercraft, at least 100 millimetres in height, and
 - (b) the vessel is operated only by personnel of that body authorised by that body to do so and only in the course of official duties, and
 - (c) particulars of the vessel (including its identification number, make, model and colour) are listed on a database maintained by that body and to which access is available to the responsible licensing official on request.
- (3) In this clause:
official duties means:
 - (a) in relation to the State Emergency Service, operating a vessel as authorised under the *State Emergency Service Act 1989* or the *State Emergency and Rescue Management Act 1989*, including for the purpose of carrying out authorised training activities, and
 - (b) in relation to Surf Life Saving New South Wales, operating a vessel while carrying out rescue or lifesaving activities, including authorised training activities.

trader means a person who manufactures, alters, repairs, tests, sells, demonstrates for a commercial purpose, or otherwise deals in, vessels or trade articles, whether on the person's own behalf or as an employee or agent.

83 Vessel registration number issued on initial registration of vessel

An initial vessel registration certificate granted by the responsible licensing official in relation to a vessel is to contain a vessel registration number.

84 Hull identification number requirements

- (1) A vessel registration certificate is not to be issued or transferred in respect of a vessel unless a hull identification number approved by RMS is affixed to the vessel in a form, manner and location that is in accordance with:
 - (a) International Standard No ISO 10087—1995 (E), *Small Craft—Hull Identification—Coding system* published by the International Organization for Standardization and as in force from time to time, or
 - (b) directions given in writing by RMS.
- (2) This clause does not apply to a commercial vessel or a regulated Australian vessel or vessel regulated under the *Navigation Act 2012* of the Commonwealth.
- (3) Despite subclause (1), a vessel registration certificate may, with the approval of the responsible licensing official, be issued or transferred without a hull identification number being affixed to the vessel. It is a condition of vessel registration that the number is affixed to the vessel within the period specified in the approval.

85 Boatcode agents

- (1) RMS may authorise a person to issue and affix hull identification numbers for the purposes of clause 84.
- (2) A person authorised under this clause must comply with any written directions of RMS in relation to the issuing or attaching of hull identification numbers.
Maximum penalty: 50 penalty units.

86 Alteration of a hull identification number

A person must not:

- (a) alter, deface, remove or obliterate a hull identification number affixed to a vessel, or
- (b) attach a different hull identification number to a vessel if a hull identification number is already affixed to the vessel.

Maximum penalty: 100 penalty units.

87 Display of vessel registration number

- (1) The owner or operator of a registered vessel must not operate the vessel, or permit the vessel to be operated, unless the vessel registration number set out in the vessel registration certificate for the vessel:
 - (a) is displayed:
 - (i) in the case of a sailing vessel, on the transom or on each side of the vessel, or
 - (ii) in any other case, on each side of the vessel, and
 - (b) contains figures that are:
 - (i) in the case of a personal watercraft or sailing vessel, at least 100 millimetres high, or
 - (ii) in any other case, at least 150 millimetres high, and
 - (c) is in a contrasting colour to the hull so that it is clearly distinguishable.Maximum penalty: 50 penalty units.
- (2) The owner or the operator of a registered vessel must not operate the vessel, or permit the vessel to be operated, if any vessel registration number that is required by this clause to be displayed on the vessel is in any way defaced, obliterated or concealed.
Maximum penalty: 50 penalty units.

88 Removal of vessel registration number

The owner of a formerly registered vessel the registration of which has been cancelled by the responsible licensing official must, within 24 hours of being notified of that cancellation remove any vessel registration number displayed on the vessel.

Maximum penalty: 50 penalty units.

89 Personalised vessel registration

- (1) A personalised vessel registration number may be issued by RMS, on request and payment of the relevant fee, for any period which RMS considers appropriate.
- (2) RMS may refuse to issue, or may cancel or suspend, a personalised vessel registration number if RMS considers that the number is or could be offensive.

90 Transfer of registrable vessel ownership

- (1) An owner of a registrable vessel who transfers the ownership of the vessel to another person must, within 21 days after the transfer, send notification of the transfer to RMS in a form that is approved by RMS.
Maximum penalty: 20 penalty units.
- (2) A person to whom ownership of a registrable vessel is transferred must, within 21 days after acquiring ownership of the vessel submit an application in a form approved by RMS to transfer the registration of the vessel.
Maximum penalty: 20 penalty units.
- (3) On receipt of an application to transfer the registration of a vessel, RMS may, if RMS considers it appropriate to do so, issue a new vessel registration number for the vessel.
- (4) If RMS issues a new registration number for the vessel, RMS is to notify the new owner of the vessel in writing of the new vessel registration number.
- (5) An owner of a vessel who receives a notification under subclause (4) in relation to the vessel:
 - (a) must change the registration number on the vessel to the new registration number within 7 days after receiving the notification, and
 - (b) if the notification requires the owner to have the vessel inspected by an authorised officer within a specified period, must present the vessel to be so inspected within that period.Maximum penalty: 50 penalty units.

91 Disposal of a registrable vessel

If a registrable vessel is lost, destroyed or disposed of (otherwise than by means of the transfer of ownership of the vessel), the owner of the vessel must inform RMS in writing of the fact within 21 days after it occurs.

Maximum penalty: 20 penalty units.

92 Condition of personal watercraft registration relating to unlicensed operation of watercraft

It is a condition of the vessel registration for a personal watercraft that the holder of the vessel registration certificate must ensure that the watercraft is not operated by a person unless the person holds a personal watercraft driving licence that authorises the person to operate the watercraft.

Maximum penalty: 50 penalty units.

93 Unauthorised operation of vessel

A person must not operate a registered vessel, or permit a registered vessel in the person's custody to be operated, without the authority or consent of the holder of the vessel registration certificate for the vessel.

Maximum penalty: 50 penalty units.

Division 3 Aquatic licences

94 Aquatic activities to be licensed

- (1) A person must not conduct an aquatic activity unless the person is the holder of an aquatic licence in respect of the aquatic activity and is conducting the aquatic activity in accordance with the conditions of the licence.

Maximum penalty: 100 penalty units.

- (2) A person is not required to hold an aquatic licence to conduct any of the following activities in or on navigable waters if the conduct of the activity will not restrict the availability of those waters for normal use by members of the public or vessel operators or cause an increased risk of danger to the public or vessel operators and complies with any conditions advised by the licensing official:
 - (a) an aquatic activity comprised of or involving the use of surfboards or other similar craft including stand up paddle boards, or
 - (b) a swimming competition, or
 - (c) a fishing competition, or
 - (d) an aquatic activity conducted by Surf Life Saving New South Wales or a surf life saving club affiliated with it if all the participants in the activity are qualified members of the body conducting the activity, or
 - (e) any other aquatic activity approved by the Minister in writing, when conducted in accordance with any conditions approved by the Minister in writing.
- (3) Subclause (1) does not apply to an aquatic activity conducted in accordance with a certificate of operation for hire and drive vessels issued in accordance with the National law.

95 Classification of aquatic licences

The following are classes of aquatic licences:

- (a) a licence for commercial aquatic activities,
- (b) a licence for all other (non-commercial) aquatic activities.

96 Purpose of aquatic licences

An aquatic licence may authorise (for a maximum period of 14 days on each occasion) any or all of the following:

- (a) the conduct of one or more than one aquatic activities by the licence holder,
- (b) the conduct of an aquatic activity on more than one occasion,
- (c) the exclusive use of an area of navigable waters for the conduct of an aquatic activity.

97 Additional requirements for applications

- (1) An application for an aquatic licence must:
 - (a) describe the proposed aquatic activity to which the application relates, and
 - (b) specify the navigable waters to which the application relates, and
 - (c) specify any land that adjoins those navigable waters that the applicant intends to use in connection with the proposed aquatic activity or is likely to be affected by the proposed aquatic activity, and
 - (d) specify the duration of the proposed aquatic activity, and
 - (e) specify the period for which the aquatic licence is intended to have effect.
- (2) The responsible licensing official may require the following information or documentation to be provided by an applicant for an aquatic licence in addition to any other information or documentation that is required to be provided by this Regulation in relation to the application:
 - (a) documentary evidence that the conduct of the proposed aquatic activity will be in accordance with the requirements of any relevant government agency,

- (b) a form of indemnity and release, approved by RMS, in relation to the conduct of the proposed aquatic activity and in favour of the Minister, the Crown and RMS.
- (3) The responsible licensing official may require the applicant to pay an additional fee to cover any costs reasonably incurred by the Minister in the publication of a notice under section 12 of the Act in connection with the event to which the application relates.

Division 4 Boat driving licences

98 Classification of boat driving licences

- (1) The following are classes of boat driving licences:
 - (a) general boat driving licence,
 - (b) personal watercraft driving licence.
- (2) A person who holds a personal watercraft driving licence is also taken to hold a general boat driving licence.

99 Certain vessels and persons exempt from requirements relating to boat driving licences

- (1) A vessel is exempt from section 63 of the Act if the vessel:
 - (a) is not a personal watercraft, and
 - (b) is not being operated at a speed of 10 knots or more.
- (2) Subclause (1) does not exempt a person from section 63 of the Act if:
 - (a) the person holds a boat driving licence that is suspended, or
 - (b) the person has held a boat driving licence that has been cancelled and the person is disqualified from applying for another such licence.
- (3) A person is exempt from section 63 of the Act if the person:
 - (a) is not ordinarily resident in this State, and
 - (b) has been operating power-driven recreational vessels in State waters for less than 3 months, and
 - (c) is licensed under the law of another country to operate a vessel of the type concerned and is operating the vessel in accordance with the conditions of that licence to the extent that those conditions are capable of applying in this State.
- (4) A person is exempt from section 63 of the Act if the person:
 - (a) is completing practical boating training conducted by a registered training organisation for a personal watercraft driving licence, and
 - (b) is under the immediate supervision of a trainer 18 years of age or older who holds a valid personal watercraft driving licence and has held that licence for a period longer than 2 years.
- (5) A person is under the immediate supervision of another person if that other person is present on the personal watercraft and is able to immediately take control of the personal watercraft.

Note. Section 63 of the Act requires persons operating power-driven recreational vessels as master to hold a boat driving licence. Sections 62 and 64 of the Act contain exemptions from that requirement and also enable the regulations to exempt vessels and persons from that requirement.

100 Licence requirements for hire and drive vessels

- (1) The operator of a hire and drive personal watercraft must hold a personal watercraft driving licence.
Maximum penalty: 20 penalty units.
- (2) An operator of a hire and drive vessel, other than a personal watercraft, must hold a boat driving licence if the vessel is operated at 10 knots or more.
Maximum penalty: 20 penalty units.
- (3) In this clause:
hire and drive personal watercraft means a personal watercraft that is let for hire and reward or for any other consideration and that is not used for a commercial purpose by the person to whom it is let.

101 Additional requirements for applications for boat driving licences

- (1) An applicant for a boat driving licence must be at least 12 years of age.
- (2) A boat driving licence is not to be issued unless the applicant for the licence:
 - (a) has produced evidence satisfactory to the responsible licensing official of the applicant's age, and
 - (b) has produced, when aged less than 16 years, written evidence of parental or guardian consent to the application, and
 - (c) has passed any practical test or examination conducted in accordance with this clause that is required by the responsible licensing official or has attained any qualification that the responsible licensing authority considers necessary, and
 - (d) has passed an eyesight test if required by the responsible licensing official, and
 - (e) has passed any medical examinations, and produced any medical reports, that the responsible licensing official considers necessary, and
 - (f) has attended any courses or practical boating training conducted in accordance with this clause that the responsible licensing authority considers necessary, or has attained any qualification that the responsible licensing authority considers necessary.
- (3) A course is conducted in accordance with this clause if:
 - (a) the course is conducted by a training organisation that is registered with the Australian Skills Quality Authority, and
 - (b) there is an agreement in place between the training organisation and RMS.
- (4) Practical boating training is conducted in accordance with this clause if the training is conducted in accordance with guidelines issued by RMS.
- (5) The responsible licensing official may refuse to issue a boat driving licence if the applicant has had a similar licence or authorisation suspended or cancelled under the laws of the Commonwealth or another State or a Territory for disciplinary reasons.
- (6) For the purposes of this Division, an applicant for, or the holder of, a boat driving licence who was born on 29 February in any year is taken to have been born on 28 February.

102 Conditions of boat driving licences

- (1) It is a condition of each boat driving licence that the holder of the licence:
 - (a) undergo and pass any examinations and tests required by the responsible licensing official regarding knowledge of the law or safe and proper practice in relation to the operation of vessels, and

- (b) attend any courses or seminars that the responsible licensing official considers necessary, and
 - (c) undergo and pass any eyesight test or medical examination required by the responsible licensing official,
- whether or not the holder of the licence has previously undergone similar examinations and tests or attended similar courses and seminars.
- (2) It is a condition of each boat driving licence that the holder of the licence must not operate a vessel if the holder becomes aware of any circumstance, condition or injury that might cast doubt on the holder's fitness to operate a vessel as authorised by the licence.

103 Restrictions applying to boat driving licence holders under 16 years

The holder of a general boat driving licence or a personal watercraft driving licence who is less than 16 years of age must not do any of the following, except in accordance with an aquatic licence:

- (a) drive a vessel at a speed greater than 20 knots,
- (b) drive a vessel in any race, display, regatta, exhibition or similar operation,
- (c) drive a personal watercraft:
 - (i) without the holder of a personal watercraft driving licence who is 18 years of age or older being present on the personal watercraft, or
 - (ii) between sunset and sunrise, or
 - (iii) while the vessel is towing any person,
- (d) drive any vessel, other than a personal watercraft, at a speed of 10 knots or more:
 - (i) without the holder of a general boat driving licence who is 16 years of age or older being present in the vessel, or
 - (ii) between sunset and sunrise, or
 - (iii) while the vessel is towing any person.

Maximum penalty: 20 penalty units.

104 Disqualification of certain persons from holding boat driving licences

- (1) A person who commits an offence under section 63 of the Act by driving a personal watercraft on navigable waters without being the holder of a marine safety licence (whether or not a licence to which this Part applies) authorising the driver to drive the watercraft may be disqualified by the responsible licensing official from holding or obtaining a boat driving licence:
- (a) for the first such offence—for a period of up to 1 year after the commission of the offence, or
 - (b) for any subsequent such offence—for a period of up to 2 years after the commission of the offence.

The disqualification is in addition to any penalty imposed for the offence.

- (2) Subject to subclause (3), the responsible licensing official may at any time remove, or reduce the period of, a disqualification imposed by subclause (1).
- (3) A disqualification imposed by subclause (1) does not operate to the extent to which it is inconsistent with any order of a court, or any decision of the responsible licensing official under section 38 of the Act, that disqualifies the person concerned from holding or obtaining a licence.

- (4) For the purposes of this clause, a person is taken to have committed an offence at the time that the person:
- (a) is convicted of the offence by a court, or
 - (b) pays the penalty required by a penalty notice served on the person under section 126 of the Act in respect of the alleged offence (or if the person does not pay the penalty and does not elect to have the matter dealt with by a court, at the time that enforcement action is taken against the person under Division 3 or 4 of Part 4 of the *Fines Act 1996*).

Division 5 Marine pilot's licences

105 Additional requirements for applications for marine pilot's licences

- (1) A marine pilot's licence is not to be issued unless the applicant for the licence:
- (a) meets the health requirements set out in the marine pilotage code, and
 - (b) holds a relevant qualification, and
 - (c) provides evidence that the applicant is competent to carry out unsupervised duties as a marine pilot in the relevant pilotage port in accordance with the marine pilotage code.
- (2) For the purposes of this clause, a **relevant qualification** is:
- (a) a certificate of competency issued under *Marine Order 70 (Seafarer certification) 2014*, made pursuant to the *Navigation Act 2012* of the Commonwealth, as master for the gross tonnage of vessel to be piloted, or
 - (b) a certificate of recognition issued under *Marine Order 70 (Seafarer certification) 2014*, made pursuant to the *Navigation Act 2012* of the Commonwealth, in relation to an international qualification equivalent to a certificate referred to in paragraph (a), or
 - (c) the equivalent of a marine pilot's licence issued in another Australian jurisdiction (other than a coastal pilot licence issued under *Marine Order 54 (Coastal pilotage) 2014*, made pursuant to the *Navigation Act 2012* of the Commonwealth) and at least one year's experience piloting all vessels in the port to which that licence relates (but only if the vessels are of a similar tonnage to those to which the application relates), or
 - (d) a demonstrated level of competency that is, in the opinion of the responsible licensing official, equivalent to a qualification referred to in paragraph (a), (b) or (c).

106 Conditions of marine pilot's licences

- (1) It is a condition of each marine pilot's licence that the holder of the licence must:
- (a) satisfactorily complete any training as required under the marine pilotage code, and
 - (b) undergo any health assessment as required under the marine pilotage code, whether or not the holder of the licence has previously undergone similar training or assessments.
- (2) It is a condition of each marine pilot's licence that the holder of the licence must not act as a marine pilot if the holder becomes aware of any circumstance, condition or injury that might cast doubt on the holder's fitness to act as a marine pilot as authorised by the licence.
- (3) It is a condition of each marine pilot's licence that the holder of the licence maintain the records required to be maintained by the marine pilotage code.

Division 6 Marine pilotage exemption certificates

107 Additional requirements for applications for marine pilotage exemption certificates

A marine pilotage exemption certificate is not to be issued unless the applicant for the certificate:

- (a) holds a certificate of competency that authorises the applicant to be a master of the vessel to which the application relates, and
- (b) has satisfactorily completed the training required by the marine pilotage code and passed an examination approved by the responsible licensing official, and
- (c) provides evidence, in accordance with the marine pilotage code, that the applicant is competent to carry out unsupervised movements of the vessel to which the certificate relates in the relevant pilotage port, and
- (d) meets the eyesight requirements of the *National Standard for Commercial Vessels Part D Crew competencies*, for the certificate of competency held by the applicant to which the application relates.

108 Conditions of marine pilotage exemption certificates

It is a condition of each marine pilotage exemption certificate that the holder of the certificate:

- (a) must satisfactorily complete any training as required under the marine pilotage code whether or not the holder of the certificate has previously undergone similar training, and
- (b) must hold a certificate of medical fitness as required by this Regulation for the certificate of competency held as a master of the vessel to which the certificate relates, and
- (c) must not move a vessel in the relevant pilotage port other than the vessel specified in the certificate, and
- (d) must not move a vessel in the relevant pilotage port if the holder becomes aware of any circumstance, condition or injury that might cast doubt on the holder's fitness to conduct such movements as are authorised by the certificate, and
- (e) must maintain the records required to be maintained by the marine pilotage code, and
- (f) must comply with any direction given by the relevant harbour master, and
- (g) must comply with any port procedures published by the relevant harbour master or the responsible licensing official.

109 Vessels for which marine pilot exemption certificates are not valid

A marine pilotage exemption certificate is not to be issued in respect of the following vessels:

- (a) a vessel the length of which exceeds 215 metres, unless approved by the responsible licensing official,
- (b) a recreational vessel the length of which exceeds 30 metres, unless approved by the responsible licensing official,
- (c) a vessel with a single person bridge operation,
- (d) a vessel that is nuclear powered,
- (e) a vessel carrying dangerous or hazardous goods in bulk, unless approved by the responsible licensing official,

- (f) a vessel or class of vessels that, in the opinion of the responsible licensing official, poses a threat to the safety of life or port property,
- (g) any vessel determined by the responsible licensing official, by notice in writing given to the master or owner of the vessel, as a vessel for which a marine pilotage exemption certificate is not to be issued,
- (h) any class of vessel determined by the responsible licensing official, by order published on the NSW legislation website, as a class of vessel for which a marine pilotage exemption certificate is not to be issued.

Division 7 Certificates of local knowledge

110 Additional requirements for applications for certificates of local knowledge

A certificate of local knowledge is not to be issued unless the applicant for the certificate:

- (a) holds a certificate of competency that authorises the applicant to be a master of the type of vessel to which the application relates, and
- (b) has satisfactorily passed an examination approved by the relevant harbour master for the pilotage port, and
- (c) provides evidence that the applicant is competent to carry out unsupervised movements of the type of vessel to which the certificate relates in the relevant pilotage port to the satisfaction of the relevant harbour master, and
- (d) meets the medical requirements of the *National Standard for Commercial Vessels, Part D Crew competencies*, for the certificate of competency held by the applicant to which the application relates.

111 Conditions of certificates of local knowledge

It is a condition of each certificate of local knowledge that the holder of the certificate:

- (a) must satisfactorily complete any training as required under the marine pilotage code whether or not the holder of the certificate has previously undergone similar training, and
- (b) must hold a certificate of medical fitness as required by the National Law for the certificate of competency held as a master of the type of vessel to which the certificate relates, and
- (c) must not carry out any unsupervised vessel movements if the holder becomes aware of any circumstance, condition or injury that might cast doubt on the holder's fitness to carry out such movements as are authorised by the certificate, and
- (d) must maintain the records required to be maintained by the marine pilotage code, and
- (e) must comply with any direction given by the relevant harbour master, and
- (f) must comply with any port procedures published by the relevant harbour master or the responsible licensing official.

112 Vessels for which certificates of local knowledge are not valid

A certificate of local knowledge is not to be issued in respect of the following vessels:

- (a) a vessel the length of which exceeds 80 metres unless approved by the responsible licensing official,
- (b) a vessel that is nuclear powered,

- (c) a vessel carrying dangerous or hazardous goods in bulk, unless approved by the responsible licensing official,
- (d) a vessel or class of vessels that, in the opinion of the responsible licensing official, poses a threat to the safety of life or port property.

Division 8 Bar crossings by certain commercial vessels

113 Application of Part

This Part applies to Class 1 and Class 2 commercial vessels that are carrying passengers.

Note. Clause 121 contains other requirements relating to bar crossings for vessels.

114 Authorisation required for bar crossings for certain commercial vessels

- (1) The master of a vessel to which this Part applies must not operate the vessel across a coastal bar unless the master holds a marine safety licence that authorises the crossing of the coastal bar.

Maximum penalty: 50 penalty units.

- (2) The owner of a vessel is guilty of an offence if the vessel is operated in contravention of subclause (1).

Maximum penalty: 50 penalty units.

115 Requirements on masters of certain commercial vessels in relation to bar crossings

- (1) The master of a vessel to which this Part applies must ensure that, when the vessel is crossing a coastal bar, each person on board the vessel who is a passenger or special personnel:

- (a) is in an open area in the after part of the vessel, and
- (b) is wearing an appropriate lifejacket.

Maximum penalty: 50 penalty units.

- (2) The master of a vessel to which this Part applies must not cross a coastal bar if the wind speed is more than 20 knots or the swell height is more than 2 metres.

Maximum penalty: 50 penalty units.

Part 6 Safety equipment and facilities

Division 1 Preliminary

116 Vessels exempt from certain requirements of Part

- (1) This Part does not apply to the following vessels:
 - (a) a vessel (other than a personal watercraft) used in connection with lifesaving or surf rescues by a local council,
 - (b) a vessel (other than a personal watercraft) used in connection with lifesaving, surf rescues, a competition or training conducted by a club affiliated with:
 - (i) the Royal Life Saving Society—Australia, or
 - (ii) Surf Life Saving Australia Limited, or
 - (iii) Surf Life Saving New South Wales,
 - (c) a rowing shell on enclosed waters.
- (2) Division 2 (except to the extent that it imposes requirements relating to lifejackets) does not apply to the following vessels:
 - (a) a personal watercraft on enclosed waters,
 - (b) a canoe or kayak on enclosed waters,
 - (c) a sailboard or kiteboard.
- (3) Division 2 (except to the extent that it imposes requirements relating to lifejackets) and Division 4 do not apply to a vessel that:
 - (a) is not ordinarily operated in State waters, and
 - (b) has not been continuously in State waters for a period of more than 3 months, and
 - (c) complies with the requirements for the carriage of safety equipment that apply to the vessel's place of registration or home port.

117 Meaning of “appropriate lifejacket”

- (1) In this Regulation, a reference to an *appropriate lifejacket* is a reference to:
 - (a) in the case of a vessel operating in enclosed waters—a lifejacket level 50S or greater, and
 - (b) in the case of a vessel operating in open waters—a lifejacket level 100 or greater, and
 - (c) in the case of a kiteboard, sailboard, canoe, kayak, personal watercraft or off-the-beach vessel operating in any waters—a lifejacket level 50S or greater.
- (2) Despite subclause (1), a lifejacket is not an *appropriate lifejacket* for the purposes of this Regulation if:
 - (a) the lifejacket relies solely on oral inflation for buoyancy, or
 - (b) the lifejacket is not the correct size for the wearer or intended wearer.
- (3) Despite subclause (1), an inflatable lifejacket is not an *appropriate lifejacket* for the purposes of this Regulation unless:
 - (a) the lifejacket was purchased or otherwise acquired new by the current owner no more than 12 months ago, or
 - (b) the lifejacket has been serviced:
 - (i) at intervals of 12 months or less, or

- (ii) at least at such longer intervals as are indicated by the manufacturer's instructions (if any) provided for the lifejacket.
- (4) In this clause:
- lifejacket level 100** means a lifejacket that meets performance level 100 of Australian Standard AS 4758 *Lifejackets* (as in force from time to time) that complies with the requirements set out in Schedule 9 for that lifejacket.
- lifejacket level 50S** means a lifejacket that meets performance level 50S of Australian Standard AS 4758 *Lifejackets* (as in force from time to time) that complies with the requirements set out in Schedule 9 for that lifejacket.

Division 2 Responsibilities of owners and operators of recreational vessels in relation to safety equipment

118 Minimum safety equipment to be carried on recreational vessels

- (1) The owner and the operator of a recreational vessel on navigable waters must ensure that the vessel carries the safety equipment:
 - (a) specified in Part 1 of Schedule 8 in respect of the vessel, or
 - (b) if Part 2 of Schedule 8 modifies the operation of Part 1 of Schedule 8 in relation to the type of vessel concerned, in accordance with Part 1 of that Schedule as so modified.Maximum penalty: 50 penalty units.
- (2) The owner and the operator of a recreational vessel on navigable waters must ensure that the equipment required by this Regulation to be carried on the vessel complies with the standards specified in Schedule 9 in respect of the equipment.
Maximum penalty: 50 penalty units.
- (3) The owner and the operator of a recreational vessel on navigable waters must ensure that the equipment required by this Regulation to be carried on the vessel is in good condition.
Maximum penalty: 50 penalty units.
- (4) The owner and the operator of a recreational vessel on navigable waters must ensure that the equipment required by this Regulation to be carried on the vessel is maintained in accordance with the manufacturer's instructions (if any) provided for the equipment.
Maximum penalty: 50 penalty units.
- (5) The owner and the operator of a recreational vessel on navigable waters must ensure that the equipment required by this Regulation to be carried on the vessel is replaced when the manufacturer's specified expiry date (if any) for the equipment is reached.
Maximum penalty: 50 penalty units.
- (6) The owner and the operator of a recreational vessel on navigable waters must ensure that the equipment required by this Regulation to be carried on the vessel is stored or placed so as to enable quick and easy access to it.
Maximum penalty: 50 penalty units.
- (7) The owner and the operator of a recreational vessel on navigable waters must ensure that each person on board the vessel is aware of where the equipment required by this Regulation to be carried on the vessel is stored or placed.
Maximum penalty: 50 penalty units.

- (8) The owner and the operator of a recreational vessel on navigable waters that is required to carry appropriate lifejackets must ensure that the lifejackets (while not in use):
- (a) are kept clearly visible to persons on board the vessel, or
 - (b) are stored in a location that is unobstructed and marked by a clearly visible sign that has the word “lifejackets” in red letters on a white background or white letters on a red background.
- Maximum penalty: 50 penalty units.
- (9) RMS may, by notice in writing given to a person who is the owner or operator of a recreational vessel on navigable waters, request the person to provide evidence of a kind specified in the notice relating to the maintenance, condition or storage of any equipment required by this Regulation to be carried on the vessel.
- (10) A person who is given a notice under subclause (9) must not, without reasonable excuse, fail to provide the evidence requested within the time specified in the notice.
- Maximum penalty: 50 penalty units.

Division 3 Requirements to wear lifejackets

119 Application of Division

This Division applies to:

- (a) all recreational vessels in navigable waters, and
- (b) all hire and drive vessels within the meaning of the National law in navigable waters.

120 Circumstances in which lifejacket must be worn on board certain vessels

- (1) This clause applies to the following vessels:
- (a) canoes,
 - (b) kayaks,
 - (c) kiteboards,
 - (d) sailboards.
- (2) Each person on board a vessel to which this clause applies must wear an appropriate lifejacket:
- (a) when the vessel is being operated between sunset and sunrise, or
 - (b) when the vessel is being operated on open waters, or
 - (c) when the vessel is being operated in alpine waters, or
 - (d) when the person is not accompanied by another person 12 years of age or more.
- Maximum penalty: 50 penalty units.
- (3) The operator of a vessel to which this clause applies must ensure that each person on board the vessel complies with the requirements of this clause.
- Maximum penalty: 50 penalty units.

121 Circumstances in which lifejacket must be worn on board a vessel under 4.8 metres in length

- (1) Each person on board a vessel under 4.8 metres in length must wear an appropriate lifejacket:
- (a) when the vessel is being operated between sunset and sunrise, or

- (b) when the vessel is being operated on open waters, or
- (c) when the vessel is being operated in alpine waters, or
- (d) when the person is not accompanied by another person 12 years of age or more.

Maximum penalty: 50 penalty units.

- (2) The operator of a vessel must ensure that each person on board the vessel complies with the requirements of this clause.

Maximum penalty: 50 penalty units.

122 Lifejacket must be worn when crossing coastal bar

- (1) A person on board a vessel must wear an appropriate lifejacket when the vessel is crossing a coastal bar.

Maximum penalty: 50 penalty units.

- (2) A person is not guilty of an offence against subclause (1) if the person is a person other than the operator of the vessel concerned and establishes that he or she did not know, and could not reasonably have been expected to know, that the vessel was crossing a coastal bar.

- (3) For the purposes of subclause (2), a person is taken to have had knowledge that the vessel concerned was crossing a coastal bar if, before the vessel proceeded to cross the coastal bar, the operator had:

- (a) informed the person that the vessel was crossing a coastal bar, or
- (b) requested or required the person to put on a lifejacket.

- (4) The operator of a vessel must ensure that each person on board the vessel complies with subclause (1).

Maximum penalty: 50 penalty units.

123 Lifejacket must be worn on personal watercraft

- (1) Each person on board a personal watercraft must wear an appropriate lifejacket.

Maximum penalty: 50 penalty units.

- (2) The operator of a personal watercraft must ensure that any other person on the personal watercraft is wearing an appropriate lifejacket.

Maximum penalty: 50 penalty units.

124 Lifejacket must be worn by a child less than 12 years of age

- (1) A child who is less than 12 years of age is required to wear an appropriate lifejacket if the child is:

- (a) on board a vessel that is less than 4.8 metres in length, or
- (b) in an open area on board a vessel that is less than 8 metres in length and is underway.

- (2) The operator of a vessel must ensure that each child on board the vessel wears an appropriate lifejacket when required by this clause.

Maximum penalty: 50 penalty units.

125 Lifejacket must be worn when being towed by a vessel while engaged in any recreational activity

- (1) A person must wear an appropriate lifejacket if that person is being towed on or over the water by a vessel while engaged in any recreational activity.

Maximum penalty: 50 penalty units.

- (2) The operator of a vessel must ensure that each person being towed by the vessel while engaged in a recreational activity complies with this clause.

Maximum penalty: 50 penalty units.

126 Lifejacket must be worn when directed by master of a vessel

A person on board any vessel must wear an appropriate lifejacket if directed to do so by the master of the vessel.

Maximum penalty: 50 penalty units.

127 General defences

- (1) A person is not guilty of an offence under this Division of failing to wear an appropriate lifejacket on a vessel if the person is a person other than the operator of the vessel concerned and establishes that there was no available appropriate lifejacket on board the vessel at the time concerned.
- (2) The operator of a vessel is not guilty of an offence under this Division of failing to ensure that a person on the vessel was wearing an appropriate lifejacket if the operator establishes that he or she took all reasonable measures to ensure that the person was wearing an appropriate lifejacket.

Division 4 Requirements for hatches and exterior doors

128 Hatches and exterior doors—construction

- (1) This clause applies to recreational vessels the hull construction of which commenced on or after 1 January 1991.
- (2) The owner and operator of a vessel to which this clause applies must ensure that any hatch or exterior door on the vessel that can be used as a means of entering or leaving the vessel is capable of being opened from both the outside and the inside of the vessel.

Maximum penalty: 50 penalty units.

- (3) A person must not supply a vessel to which this clause applies to another person knowing that the vessel will be used, or is likely to be used, for recreational purposes unless any hatch or exterior door on the vessel that can be used as a means of entering or leaving the vessel is capable of being opened from both the outside and the inside of the vessel.

Maximum penalty: 50 penalty units.

129 Hatches and exterior doors—locking

The operator of a recreational vessel that is underway must ensure that any hatch or exterior door on the vessel that can be used as a means of entering or leaving the vessel is kept unlocked if it is reasonably practicable to do so.

Maximum penalty: 50 penalty units.

Division 5 Kill switches

130 Kill switch must be operated if available

- (1) The operator of a recreational vessel under 4.8 metres in length that is fitted with a kill switch must wear any lanyard attached to the kill switch and ensure that the key of the kill switch is engaged if the engine is turned on and in gear.

Maximum penalty: 50 penalty units.

public consultation draft

Marine Safety Regulation 2015 [NSW]
Part 6 Safety equipment and facilities

- (2) In this clause, ***kill switch*** means an automatic engine cut-off device that will activate if the operator becomes separated from the vessel.

Part 7 Miscellaneous

131 Inspection reports on public ferry wharves

- (1) This clause applies to an inspection of a public ferry wharf carried out for the purposes of providing a report as to the condition of the wharf in accordance with a notice under section 125L of the Act.
- (2) The results of an inspection to which this clause applies must be recorded in the report concerned in a form approved by the Minister and must include an assessment of the following:
 - (a) whether the wharf complies with Australian Standard AS 4997—2005 *Guidelines for the design of maritime structures* as in force from time to time,
 - (b) whether the wharf complies with the document titled *Public Ferry Wharf Safety Assessment Procedure* published on the website of RMS and as in force from time to time,
 - (c) whether the wharf is structurally adequate and fit for its purpose.

132 Maintenance plans for public ferry wharves

- (1) The Minister may, by notice in writing, require the owner or person responsible for the maintenance of a public ferry wharf to prepare a maintenance plan for the wharf and to submit the plan to the Minister within the time specified in the notice.
- (2) The notice may specify the form of, and matters to be addressed in, the maintenance plan.
- (3) A person must not fail to comply with a requirement imposed on the person under this clause.
Maximum penalty: 50 penalty units.

133 Security of blood and urine samples taken under Part 2, 3, 4 or 5 of Schedule 1 to the Act

- (1) A person, after a taking sample of blood or urine under Part 2, 3, 4 or 5 of Schedule 1 to the Act and dealing with it in accordance with clause 7 (3), 12 (1), 15 (3) or 20 (3) of that Schedule (as the case may require), must immediately place the sample in a locked security box of a type approved by the Commissioner of Police. It is to be kept in the security box until it is submitted to a prescribed laboratory in accordance with clause 7 (4), 12 (2), 15 (4) or 20 (4) of Schedule 1 to the Act.
Maximum penalty: 20 penalty units.
- (2) A person must not destroy or otherwise interfere or tamper with a sample, or a portion of a sample, of a person's blood or urine taken under Part 2, 3 or 5 of Schedule 1 to the Act except as follows:
 - (a) after the expiration of 12 months commencing on the day the sample was taken,
 - (b) in the case of a sample—by or at the direction of analyst:
 - (i) so as to permit a portion of the sample to be sent for analysis by a medical practitioner or laboratory nominated, under clause 7 (5), 12 (3) or 20 (5) of that Schedule, in an application made under the relevant clause by the person from whom the sample was taken, or
 - (ii) in the course of, or on completion of, an analysis of the sample,
 - (c) in the case of a portion of a sample—by or at the direction of the medical practitioner or laboratory nominated under clause 7 (5), 12 (3) or 20 (5) of that Schedule by the person from whom the sample was taken.

Maximum penalty: 20 penalty units.

- (3) A person must not destroy or otherwise interfere or tamper with a sample, or a portion of a sample, of a person's blood or urine taken under Part 4 of Schedule 1 to the Act except as follows:
- (a) after the expiration of 13 months commencing on the day the sample was taken,
Note. Clause 15 (11) of Schedule 1 to the Act provides that a blood or urine sample that has been provided under that clause must be destroyed by or at the direction of the analyst who has custody of the sample without being analysed if, at the expiry of 13 months after the accident concerned, no authorised officer has made a notification relating to a death (as provided under clause 15 (8)).
 - (b) in the case of a sample—by or at the direction of analyst:
 - (i) so as to permit a portion of the sample to be sent for analysis by a medical practitioner or laboratory nominated, under clause 15 (5) of that Schedule, in an application made under the relevant clause by the person from whom the sample was taken, or
 - (ii) in the course of, or on completion of, an analysis of the sample,
 - (c) in the case of a portion of a sample—by or at the direction of the medical practitioner or laboratory nominated under clause 15 (5) of that Schedule by the person from whom the sample was taken.

Maximum penalty: 20 penalty units.

134 Penalty notice offences and penalties

- (1) For the purposes of section 126 of the Act:
- (a) each offence created by a provision of the *Marine Safety Act 1998* or the regulations made under that Act specified in Column 1 of Schedule 11 is an offence for which a penalty notice may be served, and
 - (b) the penalty prescribed for each such offence is the amount specified opposite the provision in Column 2 of the Schedule.
- (2) For the purposes of section 126 of the Act:
- (a) each offence created by a provision of the *Marine Pollution Act 2012* or the regulations made under that Act specified in Column 1 of Schedule 12 is an offence for which a penalty notice may be served, and
 - (b) the penalty prescribed for each such offence is:
 - (i) in the case of an offence committed by a natural person—the amount specified opposite the provision in Column 2 of the Schedule, or
 - (ii) in the case of an offence committed by a corporation—the amount specified opposite the provision in Column 3 of the Schedule.
- (3) If the reference to a provision in Column 1 of Schedule 11 or 12 is qualified by words that restrict its operation to specified kinds of offences, an offence created by the provision is a prescribed offence only if it is an offence of a kind so specified or committed in the circumstances so specified.
- (4) For the purposes of section 126 (9) of the Act, authorised officers are prescribed as a class of persons who are law enforcement officers in relation to the offences specified in Column 1 of Schedule 11 or 12.
- (5) For the purposes of this Regulation, penalty amounts are expressed in terms of the following levels:
- Level 1** means a penalty of \$100.
Level 2 means a penalty of \$250.

Level 3 means a penalty of \$500.

Level 4 means a penalty of \$750.

Level 5 means a penalty of \$1,500.

Level 6 means a penalty of \$5,000.

135 Fees

- (1) The fees set out in Schedule 1 are payable in relation to the matters set out in that Schedule.
- (2) For the purposes of section 9M of the Act, the fees set out in Schedule 2 are payable in relation to matters done under the National law.
- (3) RMS may waive, reduce or postpone (whether wholly or in part) the payment of any fee or charge payable under the Act or this Regulation if, in the opinion of RMS, it is appropriate to do so.

136 No false representation as to whether navigation is restricted in an area

A person must not falsely represent or knowingly allow another person to falsely represent that navigation is restricted by the Minister in any area.

Maximum penalty: 50 penalty units.

137 Report of certain accidents

- (1) A report is not required to be sent under section 99 (1) of the Act in relation to a marine accident that involves only recreational vessels (other than a marine accident involving vessels participating in an aquatic activity carried out under an aquatic licence) if the accident does not result in any of the following:
 - (a) injury to any person or a fatality,
 - (b) damage to property costing more than \$5,000,
 - (c) damage, or risk of damage, to the environment.
- (2) A report is not required to be sent under section 99 (1) of the Act in relation to a marine accident involving only vessels participating in an aquatic activity carried out under an aquatic licence if the accident does not result in any of the following:
 - (a) injury to any person or a fatality,
 - (b) damage to property other than to a vessel participating in the aquatic activity,
 - (c) damage to any vessel participating in the aquatic activity costing more than \$5,000,
 - (d) damage, or risk of damage, to the environment.

138 Exemption on safety or emergency grounds

- (1) A person does not contravene a provision of this Regulation by reason only of taking action for the purpose of securing the safety of any person or avoiding significant risk to the environment.
- (2) A person does not contravene a provision of this Regulation in relation to the operation of a vessel:
 - (a) displaying an emergency patrol signal (within the meaning of clause 7) if the display has been authorised as referred to in clause 7 (1) (a) or the vessel is being operated as referred to in clause 7 (1) (b) or (c), or
 - (b) under blue lights if the vessel is operated by an accredited rescue unit (within the meaning of the *State Emergency and Rescue Management Act 1989*).

139 Exemptions by RMS

- (1) RMS may exempt any person or class of persons, or any vessel or class of vessels, from any or all of the provisions of this Regulation.
- (2) RMS may exempt vessels from compliance with a notice under section 11 of the Act.
- (3) An exemption is to be by order in writing:
 - (a) given to the person concerned or the owner or master of the vessel concerned, or
 - (b) if the exemption relates to a class of persons or vessels, published on the NSW legislation website.

Note. Section 139 of the Act contains further provisions relating to exemptions, including that exemptions may be made subject to conditions and do not apply during any period in which any such condition is not complied with.

140 Savings and repeal

- (1) Any act, matter or thing that, immediately before the repeal of the *Marine Safety (General) Regulation 2009*, had effect under that Regulation continues to have effect under this Regulation.
- (2) Despite subclause (1), the *Marine Safety (General) Exemption Order 2009* is repealed.
- (3) A young adult licence in force immediately before the repeal of the *Marine Safety (General) Regulation 2009* is taken to be, and has effect as, a general boat driving licence or personal watercraft driving licence until the date on which the young adult licence was due to expire, unless sooner suspended or cancelled.
- (4) A lifejacket that was an appropriate lifejacket for a vessel under the *Marine Safety (General) Regulation 2009*, immediately before the repeal of that Regulation, is taken to be an appropriate lifejacket for the purposes of this Regulation.
- (5) A disqualification under clause 37 or 80 of the *Marine Safety (General) Regulation 2009* in force immediately before the repeal of that Regulation continues to have effect under this Regulation.

public consultation draft

Marine Safety Regulation 2015 [NSW]
Schedule 1 Fees relating to State matters

Schedule 1 Fees relating to State matters

(Clauses 3 (1) and 134 (1))

Matter	Fee
Vessel registration:	
(a) personal watercraft	\$318
(b) personal watercraft (pensioner concession)	\$160
(c) other vessels:	
(i) vessels of not more than 3m in length	\$63
(ii) vessels of more than 3m in length—for each additional 0.5m in length (or part of 0.5m) (up to a maximum registration fee of \$628)	\$10
(iii) pensioner concession fee	50% of relevant fee in subparagraph (i) or (ii), rounded to nearest dollar
Transfer of vessel registration to a person who is not a dealer in vessels for sale	\$30
Transfer of vessel registration to a dealer in vessels for sale	\$19
Late transfer	\$35
Fix hull identification number	\$84
Validate hull identification number	\$84
New boatcode agent establishment	\$1,208
Hull identification number plates—set of 20	\$142
Hull identification number certificates—pad of 50	\$31
Transfer of boatcode agency	\$317
Personalised vessel registration	\$176
Preserve personalised registration	\$26
Registration numbers large (set of 2)	\$21
Registration numbers small (set of 2)	\$11
Registration numbers—individual	\$2
Personal watercraft driving licence examination	\$50
Personal watercraft driving licence upgrade examination	\$17
Personal watercraft driving licence (1 year)	\$116
Personal watercraft driving licence (3 years)	\$312
Personal watercraft driving licence (5 years)	\$488
Personal watercraft driving licence (10 years)	\$890

public consultation draft

Marine Safety Regulation 2015 [NSW]
Schedule 1 Fees relating to State matters

Matter	Fee
Personal watercraft driving licence—pensioner concession or persons aged under 16 years	50% of relevant licence fee (depending on duration of licence), rounded to nearest dollar
Boat driving licence examination	\$33
Boat driving licence (1 year)	\$58
Boat driving licence (3 years)	\$156
Boat driving licence (5 years)	\$244
Boat driving licence (10 years)	\$445
Boat driving licence—pensioner concession or persons aged under 16 years	50% of relevant licence fee (depending on duration of licence), rounded to nearest dollar
Application for an aquatic licence, commercial activity	\$373
Application for an aquatic licence, other than commercial activity	\$187
Waterway access fee for an aquatic licence	An appropriate market rate for the exclusive occupation of waters, as determined by RMS
Attendance by officer of RMS at special event or standard event—per hour	\$180
Bar crossing licence	\$122
Issue of replacement marine safety licence where licence is lost, stolen, damaged, destroyed or defaced	\$20
Marine safety licence late payment fee	\$35
Marine pilot's licence (initial application)	\$443
Marine pilot's licence (application to extend licence to add a new port)	\$11
Marine pilot's licence (renewal application)	\$222
Marine pilotage exemption certificate (initial application)	\$443
Marine pilotage exemption certificate (renewal application)	\$222
Certificate of local knowledge (initial application)	\$67
Certificate of local knowledge (renewal application)	\$34

public consultation draft

Marine Safety Regulation 2015 [NSW]
Schedule 1 Fees relating to State matters

Matter

Issue of notice to operator of a commercial vessel under clause 53

Fee

If exclusive use of waters is required under notice, an appropriate market rate for the exclusive occupation of waters, as determined by RMS

public consultation draft

Marine Safety Regulation 2015 [NSW]
Schedule 2 Fees relating to National law matters

Schedule 2 Fees relating to National law matters

(Clause 134 (2))

Column 1	Column 2
Matter	Fee
Issue of new Certificate of Competency Master less than 80m near coastal	\$514
Issue of new Certificate of Competency Master less than 35m near coastal, Mate less than 80m near coastal	\$470
Issue of new Certificate of Competency Master less than 24m near coastal, Master (inland waters)	\$354
Issue of new Certificate of Competency Coxswain Grade 1 near coastal, Master of Vehicular Ferry in Chains	\$178
Issue of new Certificate of Competency Coxswain Grade 2 near coastal	\$122
Issue of new Certificate of Competency Coxswain Grade 3 near coastal	\$92
Issue of new Certificate of Competency General Purpose Hand near coastal	\$61
Issue of new Certificate of Competency Engineer Class 3 near coastal	\$354
Issue of new Certificate of Competency Marine Engine Driver Grade 1 near coastal	\$354
Issue of new Certificate of Competency Marine Engine Driver Grade 2 near coastal	\$231
Issue of new Certificate of Competency Marine Engine Driver Grade 3 near coastal	\$122
Additional oral examination for a certificate of competency	\$122
Endorsement of a certificate of competency	\$122
Renewal of certificate of competency (other than general purpose hand)	\$122
Renewal of certificate of competency for general purpose hand	\$61
Issue of duplicate or replacement certificate of competency	\$122
Travel and accommodation expenses for attending an examination for a certificate of competency, at the request of an applicant, at a place or time other than that at which the examiner is normally engaged in official duties (whether or not the applicant attends for the examination)	Reasonable expenses incurred, as determined by RMS
Survey inspection during construction phase to undertake prototype plan assessment—all classes of vessels not more than 7.5m in length—per metre or part of a metre	\$153
Survey inspection during construction phase to undertake prototype plan assessment—all classes of vessels more than 7.5m in length—per metre or part of a metre	\$317

public consultation draft

Marine Safety Regulation 2015 [NSW]
Schedule 2 Fees relating to National law matters

Column 1	Column 2
Matter	Fee
Initial survey inspection where prototype plan approval has been given—all classes of vessels not more than 7.5m in length—per metre or part of a metre	\$79
Initial survey inspection where prototype plan approval has been given—all classes of vessels more than 7.5m in length—per metre or part of a metre	\$149
Initial survey inspection where prototype plan approval has not been given—all classes of vessels not more than 7.5m in length—per metre or part of a metre	\$153
Initial survey inspection where prototype plan approval has not been given—all classes of vessels more than 7.5m in length—per metre or part of a metre	\$317
Initial survey inspection where the vessel has a certificate from a recognised Classification Society (within the meaning of Part B of the NSCV)—all classes of vessels not more than 7.5m in length—per metre or part of a metre	\$79
Initial survey inspection where the vessel has a certificate from a recognised Classification Society (within the meaning of Part B of the NSCV)—all classes of vessels more than 7.5m in length—per metre or part of a metre	\$149
Periodic survey inspection—all classes of vessels not more than 7.5m in length—per metre or part of a metre—per metre or part of a metre	\$52
Periodic survey inspection—all classes of vessels more than 7.5m in length but not more than 15m in length—per metre or part of a metre	\$77
Periodic survey inspection—all classes of vessels more than 15m in length—per metre or part of a metre	\$92
Other inspections such as checking compliance with an improvement notice or assessing an equivalent solution for vessel design and construction—per hour or part of an hour	\$149
Survey inspection services carried out outside of normal working hours—per hour or part of an hour (including travel time)	\$73.71 subject to a minimum fee of \$288.71 where the hours are not merely an extension of normal working hours, in addition to the usual fee for the service
Travel and accommodation expenses for attending for an inspection of a vessel, at the request of an applicant, for a certificate of survey or other inspection relating to a certificate of survey at a place other than that at which the surveyor is normally engaged in official duties (whether or not the applicant attends)	Reasonable expenses incurred
Issue of replacement certificate of survey	\$42
Issue of new load line certificate or further certificate	\$346
Periodical inspection for load line certificate	\$116
Issue of certificate of operation for hire and drive vessels under 7.5m:	

public consultation draft

Marine Safety Regulation 2015 [NSW]
Schedule 2 Fees relating to National law matters

Column 1	Column 2
Matter	Fee
(a) base fee, and	\$214
(b) for each non power-driven vessel covered by the certificate, and	\$29
(c) for each power-driven vessel covered by the certificate	\$86
Annual fee for certificate of operation for hire and drive vessels under 7.5m	
(a) for each non power-driven vessel covered by the certificate, and	\$29
(b) for each power-driven vessel covered by the certificate	\$86
Annual fee for certificate of operation for personal watercraft	\$318
Annual fee for certificate of operation for Class 3 vessel	\$80
Annual fee for certificate of operation for all other vessels not specified above:	\$63
(a) base fee, and	\$63
(b) for each 0.5m (or part) in length that exceeds 3m (up to a maximum fee of \$628)	\$10
Transfer of certificate of operation	\$31
Issue of replacement or duplicate certificate of operation	\$43
Issue of exemption	\$122
Audit of safety management system—per metre (or part of a metre) of vessel	\$24
Issue of certificate of survey where the survey inspection has not been carried out by an RMS surveyor	\$149
Accreditation of registered training organisation— per hour or part of an hour	\$149
Audit of registered training organisation— per hour or part of an hour	\$149

Schedule 3 Partially smooth waters

(Clause 3 (1))

Port Stephens

On Port Stephens west of a line drawn across its entrance to the Tasman Sea from the north eastern extremity of Tomaree Head in a north easterly direction to the south eastern extremity of Yacabba Head.

Broken Bay

On Broken Bay west of a line drawn across its entrance to the Tasman Sea from a point on the northern extremity of Barrenjoey Head in a north easterly direction to the southern extremity of Box Head.

Port Jackson

On Port Jackson west of a line drawn across its entrance to the Tasman Sea from the western extremity of Cannae Point in a southerly direction to the northern extremity of Inner South Head.

Botany Bay

On Botany Bay west of a line drawn across its entrance to the Tasman Sea from the southern extremity of Bare Island in a southerly direction to the northern extremity of Inscription Point.

Port Hacking

On Port Hacking west of a line drawn across its entrance to the Tasman Sea from the eastern extremity of Glaisher Point in a south easterly direction to the northern extremity of Point Hacking Point.

Jervis Bay

On Jervis Bay west of a line drawn across its entrance to the Tasman Sea from the southern extremity of Dart Point in a southerly direction to the northern extremity of Governor Head.

Twofold Bay

On Twofold Bay west of a line drawn across its entrance to the Tasman Sea from the southern extremity of Worang Point in a southerly direction to the northern extremity of Honeysuckle Point.

Schedule 4 Smooth waters

(Clause 3 (1))

Tweed Heads

On the Tweed River south of a line drawn from the northernmost extremity of the Spur Wall in a north easterly direction to a point on the shore adjacent to the prolongation of Florence Street, Tweed Heads.

Brunswick Heads

On the Brunswick River upstream of a line drawn directly across the river from a point on the southern training wall at the junction with the most easterly point of the entrance to Simpsons Creek and approximately 600 metres upstream of its entrance to the Coral Sea in a generally northerly direction to a point opposite the shore.

Ballina

On the Richmond River upstream of a line drawn across the river from a point on the shore adjacent to the prolongation of Moon Street, Ballina in a south south westerly direction to a point on the opposite shore.

Evans Head

On the Evans River upstream of a line drawn directly across the river from the western extremity of an unnamed point on the eastern shore approximately 380 metres upstream of its entrance with the Coral Sea in a north westerly direction to a point on the opposite shore.

Yamba and Iluka

On the Clarence River upstream of a line drawn from the northern extremity of Hickey Island approximately 1,600 metres upstream of its entrance to the Coral Sea in a northerly direction to a point on the opposite shore.

Wooli

On the Wooli River upstream of a line drawn across the river from a point on the eastern shore approximately 1,400 metres upstream of its entrance to the Coral Sea in a westerly point to a point on the opposite shore.

Urunga

On the Bellinger and Kalang Rivers upstream of a line drawn from a point on the southern training wall approximately 1,100m upstream of its entrance to the Tasman Sea in an easterly direction to a point on the opposite shore.

Nambucca Heads

On the Nambucca River upstream of lines drawn across the river entrance channels from a point on the northern shore adjacent to the prolongation of High Street, Nambucca Heads, in a southerly direction to a point on the eastern shore of Warrell Creek at its entrance to the Nambucca River and opposite Warrell Point.

South West Rocks and Stuarts Point

On the Macleay River upstream of a line drawn across the river from a point on the southern training wall approximately 1,300m upstream from its entrance with the Tasman Sea in a generally north westerly direction to a point on the opposite northern training wall.

Port Macquarie

On the Hastings River upstream of a line drawn across the river from a point on the southern shore adjacent to the prolongation of Hay Street, Port Macquarie, in a northerly direction to a point on the opposite northern training wall.

Laurieton

On the Camden Haven River upstream of a line drawn across the river from a point on the southern training wall at Klondyke Rocks approximately 1,000m upstream of its entrance to the Tasman Sea.

Manning River

On the Manning River upstream of a line drawn across the river from a point on the northern training wall approximately 3,100m upstream of its entrance to the Tasman Sea in a south south westerly direction to the northern extremity of the southern training wall.

Wallis Lake

On Wallis Lake upstream of the Forster-Tuncurry Bridge.

Port Stephens

On Port Stephens upstream of a line drawn from the southern extremity of Corrie Island in a south easterly direction across the waterway to a point on the southern shore in line with the highest point of Tomaree Head.

Newcastle

On the Hunter River upstream of a line drawn across the river from the western extremity of Stony Point in a westerly direction to a point on the opposite northern shore 500 metres upstream from Pirate Point.

Lake Macquarie

On Lake Macquarie upstream of a line drawn across Swansea Channel from a point on the northern extremity of Coon Island in an easterly direction to a point on the eastern shore adjacent to the prolongation of Soldiers Road, Pelican.

Tuggerah Lakes

On Tuggerah Lakes west of The Entrance Bridge.

Brisbane Water

On Brisbane Water upstream of a line drawn from the western extremity of Wagstaffe Point in a generally west north westerly direction to a point on the opposite shore adjacent to the prolongation of Kourung Street, Ettalong.

Pittwater

On Pittwater south of a line drawn from a point on the shore at the western extremity of Shark Point, Barrenjoey Head in a westerly direction to the eastern extremity of First Head.

Hawkesbury River

On the Hawkesbury River upstream of a line drawn from the southern extremity of Juno Point in an easterly direction to the northern extremity of Flint and Steel Point.

Pittwater to Hawkesbury River

The area bounded by lines drawn between the western extremity of Shark Point, Barrenjoey Head to the eastern extremity of First Head and Juno Point and Flint and Steel Point, except when the wave height in any part of that area exceeds 0.5m from trough to crest.

Brisbane Water to Pittwater or Hawkesbury River

The area bounded by lines drawn between the northern extremity of Barrenjoey Head and the southern extremity of Box Head and the western extremity of Shark Point, Barrenjoey Head to the eastern extremity of First Head, except when the wave height in any part of that area exceeds 0.5 metres from trough to crest.

Port Jackson

On Port Jackson upstream of a line drawn from the western extremity of Laings Point in a west north westerly direction to the eastern extremity of Georges Head.

Middle Harbour

On Middle Harbour upstream of a line drawn from the southern extremity of Grotto Point in a southerly direction to the western extremity of an unnamed point at the south eastern end of Balmoral Beach.

Port Jackson to Middle Harbour

The area bounded by lines drawn between Dobroyd Point and Inner South Head, Laings Point and Georges Head and Grotto Point in a southerly direction to the western extremity of an unnamed point at the south eastern end of Balmoral Beach, except when the wave height in any part of that area exceeds 0.5m from trough to crest.

Botany Bay

On Botany Bay west of a line drawn from the southern extremity of Molineux Point in a south westerly direction to the north western extremity of Bonna Point.

Georges River

On the Georges River upstream of the Captain Cook Bridge.

Port Hacking

On Port Hacking upstream of a line drawn from the southern extremity of Hungry Point in a south south easterly direction to the north western extremity of an unnamed point at the south eastern end of Horderns Beach.

Port Kembla

On Port Kembla Outer Harbour west of a line drawn from the north western extremity of the southern breakwall in a northerly direction to the south eastern extremity of the northern breakwall.

Lake Illawarra

On Lake Illawarra upstream of Windang Bridge.

Crookhaven Heads

On the Crookhaven River upstream of a line drawn from the north western extremity of an unnamed point adjacent to Crookhaven Heads Regional Boat Ramp in a northerly direction to the mid point of the northern training wall.

Sussex Inlet and St George's Basin

On Sussex Inlet and St Georges Basin upstream of a line drawn across the waterway from an unnamed point at the south westerly end of Bherwerre Beach at the junction with the Tasman Sea in a westerly direction to a point on the opposite shore.

Lake Conjola

On Lake Conjola west of a line drawn across the waterway from a point adjacent the eastern side of the Boat Ramp at Lakes Entrance Caravan Park in a northerly direction to a point on the opposite shore.

Burrill Lake

On Burrill Lake upstream of a line drawn directly across the waterway from a point on the western shore adjacent to the north eastern boundary of Rotary Park.

Tabourie Lake

On Tabourie Lake westward of a line drawn in a northerly direction from the picnic area on the southern shore to the caravan park on the northern shore.

Clyde River

On the Clyde River at Batemans Bay upstream of a line drawn between the eastern side of the entrance to the boat harbour and Pinnacle Point.

Tomaga River

On the Tomaga River upstream of a line drawn across the river from a point adjacent to the Tomakin Boat Ramp at the end of Kingston Place, Tomakin to a point on the opposite shore.

Moruya River

On the Moruya River upstream of a line drawn across the waterway from a point on the southern training wall approximately 750 metres from its entrance to the Tasman Sea in a generally northerly direction to a point on the opposite shore.

Durras Lake

On Durras Lake west of a line drawn due south from the natural spring well at North Durras.

Coila Lake

On Coila Lake west of a line drawn from the Boat Ramp at the end of Foam Street, Tuross Heads in a north easterly direction to a point on the opposite northern shore.

Tuross Lake

On Tuross Lake upstream of a line drawn from the Boat Ramp off Nelson Parade, Tuross Heads in a south south westerly direction to an unnamed point on the shore of the Eurobodalla National Park.

Narooma

On the Wagonga Inlet at Narooma upstream of a line drawn from a point on the southern shore adjacent to the northern boundary of Rotary Park, Narooma in a north westerly direction to the southernmost extremity of the northern training wall.

Corunna Lake

On Corunna Lake upstream of the Princes Highway Bridge.

Wallaga Lake

On Wallaga Lake upstream of the Tilba Road Bridge.

Bermagui

On the Bermagui River upstream of a line drawn from the northern extremity of the eastern training wall in a westerly direction to a point midway along the eastern training wall.

Merimbula Lake

On Merimbula Lake upstream of a line drawn across its entrance with the Tasman Sea from an unnamed point at the junction of Mitchies Beach and Merimbula Beach in an easterly direction to a point on the opposite shore at Bar Beach.

Pambula

On the Pambula River upstream of a line drawn between Black Gin Point and the seaward end of Mosquito Bight Point.

Eden

On Twofold Bay west of a line drawn from the western extremity of the Eden Breakwall in a south easterly direction to the northern extremity of Munganoa Point.

Wonboyn

On Wonboyn River upstream of a line drawn from the north western extremity of Dollys Island in a south easterly direction to a point on the opposite northern shore.

Murray River

On the Murray River and its New South Wales tributaries and in the *transferred Victorian area* as defined in the *Marine Safety Legislation (Lakes Hume and Mulwala) Act 2001*.

Lord Howe Island Lagoon

On Lord Howe Island Lagoon inside the coral reef bounded by lines commencing in the north west adjacent to the southern shore of North Beach in a south easterly direction to Blackburn Island thence in a south easterly direction to a point on the shore at Callaghans Rock at Lovers Bay.

Other New South Wales waters

All other coastal navigable waters (such as rivers, creeks, lakes and lagoons) except those listed in Schedule 3.

All inland navigable waters (such as rivers, lakes and dam waters).

Schedule 5 Modifications to International Regulations for Preventing Collisions at Sea

(Clause 5)

Rule 1 of the International Regulations is modified by including the following NSW special Rule:

- (1) Despite Rule 1 (a), these Rules extend to vessels in all navigable waters.
- (2) These Rules do not apply to vessels taking part in an aquatic activity if the aquatic licence that authorises the activity provides for a different set of rules to be applied. However, these Rules do apply if there is a risk of collision between a vessel taking part in the aquatic activity and a vessel that is not taking part in the aquatic activity.
- (3) An unoccupied vessel is exempt from the provisions of these Rules if it is:
 - (a) secured under the authority of, and in accordance with the conditions, attached to an occupation licence issued under the *Management of Waters and Waterside Lands Regulations—N.S.W.*, or
 - (b) lawfully occupying any navigable waters by direction of, or with the permission of, the Crown or any other person or body lawfully entitled to give such a direction or permission.
- (4) Subrule (3) of this special rule does not apply to a vessel secured to a shipping mooring.

Rule 18 of the International Regulations is modified by including the following NSW special Rule:

- (1) In this special Rule, ***priority over sail signal*** means a signal displaying an orange diamond shape.
- (2) In addition to complying with the requirements of Rule 18, the operator of a sailing vessel must keep out of the way of, and keep a safe distance from, a vessel displaying a priority over sail signal.
- (3) If the operator of a sailing vessel is unable to comply with subrule (2) of this special Rule, the operator is to make that fact clear to the operator of the vessel displaying the priority over sail signal as soon as possible.
- (4) The operator of a vessel must not display a priority over sail signal without the written consent of the Minister.

Rule 23 of the International Regulations is modified by including the following NSW special Rule:

- (1) In this special Rule, ***commuter craft zone*** means the following areas of water:
 - (a) Hawkesbury River Area—being the navigable waters of that part of Hawkesbury River and tributaries (including Mullet, Mooney Mooney, Mangrove and Berowra Creeks) upstream of a line between Green Point and Croppy Point to a line across the River from an unnamed point, approximately 1 kilometre south of the entrance to Breakfast Creek, (near Spencer) to Gentlemans Halt,
 - (b) Pittwater Area—being the navigable waters of that part of Pittwater and tributaries lying south of a line extending from the western extremity of Observation Point northwesterly to an unnamed point at the northern extremity of Great Mackerel Beach,

public consultation draft

Marine Safety Regulation 2015 [NSW]
Schedule 5 Modifications to International Regulations for Preventing Collisions at Sea

- (c) Woronora Area—being the navigable waters of that part of Woronora River and tributaries lying south of a line extending in an easterly direction from an unnamed point (approximately 250 metres northeast of the entrance to Still Creek) to the opposite shore of the River,
 - (d) Port Hacking Area—being the navigable waters of that part of Port Hacking and Gunnamatta Bay commencing at the eastern extremity of Cabbage Tree Point thence by the shore of Bundeena Bay to the eastern extremity of Gunyah Beach thence by a line extending northwesterly across Port Hacking to the western extremity of Hungry Point thence by the shore of Gunnamatta Bay to the eastern extremity of Burraneer Point thence by a line extending southeasterly across Port Hacking to the point of commencement.
- (2) A power-driven vessel less than 5 metres in length may exhibit sidelights and a sternlight instead of the lights prescribed by Rule 23 (a) and (d) when underway in a commuter craft zone.
 - (3) The operator of a vessel in chains must ensure that between sunset and sunrise the vessel displays, instead of the lights prescribed by Rule 23:
 - (a) an all round flashing light (within the meaning of Rule 21) when underway, and
 - (b) an all round green light situated not less than 1 metre vertically above the red light at the forward end of the vessel to indicate the direction in which the vessel is proceeding when underway, and
 - (c) an all round red light at each end of the vessel in a horizontal line at a height of not less than 3 metres above the deck of the vessel if the vessel is available to operate but is not underway.
 - (4) A high speed catamaran ferry may, with the written consent of the Minister, exhibit an all round flashing yellow light (within the meaning of Rule 21).

Rule 27 of the International Regulations is modified by including the following NSW special Rule:

- (1) The owner and operator of a vessel engaged in diving operations, and any diver engaged in those operations from the vessel, must ensure that a rigid replica of an International Code flag “A” is displayed on the vessel, or on a buoy or float positioned nearby, so as to make it clearly visible and that:
 - (a) the top of the flag is at least 1 metre from the top of any part of the vessel’s superstructure or other obstruction or at least 2 metres from the water surface if mounted on a nearby buoy, and
 - (b) the flag is visible through 360°, and
 - (c) the flag is at least 400 millimetres by 400 millimetres in size, and
 - (d) the flag is not faded, and
 - (e) the flag is maintained in good condition.
- (2) The operator of a vessel underway must maintain a safe distance from, and travel at a safe speed when in the vicinity of, an area in which a replica of an International Code flag “A” is displayed.
- (3) Rule 27 (g) does not operate so as to exempt any vessel which is engaged in dredging operations or underwater operations from the requirements of that Rule in relation to the exhibition of lights and shapes.

public consultation draft

Marine Safety Regulation 2015 [NSW]
Schedule 5 Modifications to International Regulations for Preventing Collisions at Sea

Rule 29 of the International Regulations is modified by including the following NSW special Rule

In addition to the requirements of Rule 29, a vessel engaged on pilotage duty between sunrise and sunset must exhibit when underway a flag that is of a size not less than 900 millimetres by 600 millimetres and is divided horizontally in 2 colours (the upper half being white and the lower half being red).

Schedule 6 Waters in which kitesurfing and sailboarding prohibited

(Clause 15)

Part 1 Waters in which kitesurfing prohibited

The waters of Port Jackson, including the waters of all tidal bays, rivers and their tributaries connected or leading to Sydney Harbour bounded by high water mark and lying to the west of a line commencing at the southernmost point of North Head and running to the northernmost point of South Head.

Part 2 Waters in which sailboarding prohibited

The navigable waters of that part of the Port of Sydney:

- (a) enclosed by the imaginary line commencing at mean high water mark of the South Pacific Ocean near the northern extremity of South Head (which bears 130 degrees from Hornby Light) and thence bearing 130 degrees to the seaward limit of the Sydney Harbour boundary as defined in clause 6 of Schedule 1 to the *Ports and Maritime Administration Regulation 2012* thence generally north-easterly by that Port boundary (being the arc of a circle of radius 5,559 metres having at its centre Hornby Light) to a point bearing 90 degrees from mean high water mark at the southern extremity of North Head thence bearing 270 degrees to that southern extremity of that Head thence generally north-westerly by mean high water mark to Cannae Point thence north-westerly to a point bearing 270 degrees 185 metres distant from the western extremity of Smedleys Point thence north-easterly to a point in mean high water mark beneath the eastern side of Manly Wharf East thence north-easterly by mean high water mark to a point beneath the western side of the Manly Ferry Jetty thence south-westerly firstly to a point bearing 222 degrees 750 metres distant from that lastmentioned point and thence passing through the starboard hand buoy off Middle Head to a point bearing 180 degrees 92 metres distant from the Bradley's Head Light thence north-westerly passing through the Athol Bight Mooring Buoys numbers 4, 5 and 6 to mean high water mark at the inshore end of the southern side of Kirribilli Ferry Wharf, thence upstream by mean high water mark of the Port of Sydney including all bays and inlets to the eastern extremity of Manns Point, thence across Parramatta River to mean high water mark at the inshore end of the western side of Long Nose Point Ferry Wharf thence downstream by mean high water mark of the Port of Sydney including all bays and inlets to a point which bears 225 degrees from the Man o' War Naval buoy situated northerly of Elizabeth Bay thence north-easterly passing through that Man o' War Naval buoy, the white navigation tower situated northerly of Shark Island, the yellow buoy situated westerly of Vaucluse Point, the port hand channel marker situated south-westerly of Sow and Pigs to the junction Buoy thence south-easterly to mean high water mark at the northern extremity of South Head and thence generally south-easterly by mean high water mark to the point of commencement, and
- (b) within the fifth and sixth spans from the northern end of the bridge known as the Ryde Road Bridge located approximately 140 metres upstream from Mortlake Point, and
- (c) within the third and fourth spans from the northern end of the bridge known as the Ryde Rail Bridge located approximately 210 metres upstream from Mortlake Point, and
- (d) despite paragraph (a), within 50 metres of any public wharf of any of the following commercial mooring buoys or any vessel moored to such a buoy:
 - (i) the Naval Buoys in Chowder Bay,
 - (ii) the Athol Bight Mooring Buoys,
 - (iii) the Point Piper Explosive Buoys,
 - (iv) the Man-of-War Anchorage Naval Buoys,
 - (v) the Naval Buoys in the vicinity of Spectacle and Snapper Islands,

public consultation draft

Marine Safety Regulation 2015 [NSW]
Schedule 6 Waters in which kitesurfing and sailboarding prohibited

- (vi) the Naval Buoys in Hunter Bay, Middle Harbour.

Schedule 7 Requirements relating to Sydney Cove

(Clauses 36 and 58)

1 Definition

In this Schedule:

Sydney Cove means the whole of that portion of Sydney Harbour that lies south of an imaginary line drawn from the position of the fixed red beacon on Dawes Point to the position of the fixed red beacon on Bennelong Point.

Note. A map of Sydney Cove is available on the RMS website.

2 Approvals required

- (1) A vessel must not enter or operate in Sydney Cove unless:
 - (a) written approval has been obtained from RMS, Transport for NSW or the Port Authority of New South Wales, or
 - (b) there is an approved wharf booking for the vessel that has been given by RMS, Transport for NSW or the Port Authority of New South Wales.
- (2) No sailing vessel may operate in Sydney Cove with sails hoisted except with the written approval of RMS.

3 General navigation requirements

- (1) A vessel must not be operated within 100 metres of the Port Lateral Marker at Bennelong Point, unless the vessel is departing from:
 - (a) Sydney Cove Wharf 3, or
 - (b) Sydney Cove Wharf 2, or
 - (c) the Eastern Pontoon.
- (2) A vessel must not be operated within 100 metres of the Dawes Point siren unless the vessel is entering Sydney Cove to berth in:
 - (a) Sydney Cove Wharf 5, or
 - (b) Sydney Cove Wharf 6, or
 - (c) the Harbour Masters Steps, or
 - (d) the Commissioners Steps, or
 - (e) Campbells Cove.

4 North/south rule

- (1) Subject to this clause, a vessel must be operated on a northerly or southerly course within Sydney Cove.
- (2) A vessel departing Sydney Cove to a place west of Sydney Cove must be operated on a northerly course until altering course to port to pass north of the diamond shape marking the centre of the Harbour Bridge unless it is clearly safer to do otherwise.
- (3) However, a vessel may be operated other than on a northerly or southerly course while within Sydney Cove if:
 - (a) the vessel is being manoeuvred as required to relocate between Wharves 2, 3, 4, 5 or 6, in circumstances when it is safe to do so, or
 - (b) the vessel is restricted in its ability to manoeuvre.

5 The waiting line

- (1) A vessel entering Sydney Cove that is required to wait for a berth to become vacant must wait north of the waiting line.
- (2) A vessel must not leave its berth in Sydney Cove unless there are no inbound vessels south of the waiting line that will hinder the departure of the vessel.
- (3) In this clause:
waiting line means the imaginary line drawn between the knuckle located at the northern end of the Sydney Cove Passenger Terminal building and the knuckle in the Opera House sea wall, located 150 metres south of Bennelong Point.

6 Special requirements for water taxis

- (1) A water taxi waiting for the use of Commissioners and Harbour Masters Steps must remain west of the taxi waiting line west.
- (2) A water taxi waiting for the use of the Eastern Pontoon must remain east of the taxi waiting line east.
- (3) Another vessel must not be permitted to raft up to a water taxi in Sydney Cove.
- (4) Passengers on a water taxi must not be permitted to embark or disembark at wharves 2, 3, 4, 5 or 6 at Sydney Cove.
- (5) A water taxi must give berthing priority to another vessel for which there is an approved wharf booking.
- (6) In this clause:
taxi waiting line east means an imaginary line drawn along the western face of the Eastern Pontoon parallel to the sea wall extending south to the sea wall.
taxi waiting line west means an imaginary line drawn along the face of the Overseas Passenger Terminal wharf extending south to the sea wall.

7 Control of hull or propeller wash

- (1) A vessel in Sydney Cove must not be operated in a manner that directs any propeller wash towards the Commissioners or Harbour Masters Steps when vessels are alongside those berths.
- (2) A vessel must not be operated so as to generate excessive hull or propeller wash within Sydney Cove.

8 Berthing of certain vessels at Eastern Pontoon

- (1) A vessel more than 12 metres in length berthing at the Eastern Pontoon must be berthed port side to except with the written approval of RMS.
- (2) When departing the Eastern Pontoon, a vessel berthed port side must be operated astern until the vessel is at least 200 metres to the north, then turned to starboard to head the vessel on a northerly course to leave Sydney Cove.
- (3) A vessel departing the Eastern Pontoon must not hinder the operation of any other vessel in Sydney Cove.

9 Berthing of vessels in Sydney Cove without approved wharf bookings

- (1) This clause applies to a vessel in Sydney Cove that does not have an approved wharf booking.
- (2) At least one member of the crew of a vessel to which this clause applies must:
 - (a) remain on board the vessel, or within 5 metres of the vessel if ashore, and

- (b) keep watch in relation to the safety of the vessel, other vessels in Sydney Cove and any person boarding or on-board the vessel.

10 Vessels entering or leaving Campbells Cove

- (1) A vessel entering or leaving Campbells Cove must be manoeuvred as close to the entrance to Campbells Cove as safe navigation permits so as not to impede other Sydney Cove traffic.
- (2) This clause does not affect the requirements of clause 4.

11 Communications on VHF Channel 13

- (1) The master of a vessel in Sydney Cove must monitor VHF Channel 13 at all times while the vessel is in Sydney Cove.
- (2) The master of a vessel in Sydney Cove must immediately advise Sydney Ports Vessel Traffic Service on VHF Channel 13 of any matter affecting safe navigation of a vessel in Sydney Cove.

Schedule 8 Minimum safety equipment to be carried on recreational vessels

(Clause 118 (1))

Part 1 General requirements for safety equipment

Essential items	Quantity	Area of operation	
		Enclosed	Open
Anchor with chain/line	1	Yes	Yes
Appropriate lifejacket	1 for each person on board the vessel	Yes	Yes
Appropriate map or chart	1	No	Yes
Bailer/bucket/fire bucket	1	Yes	Yes
Bilge pump (B1)	(B2)	Yes	Yes
Compass	1	No	Yes
Distress signals			
Orange smoke hand-held distress signal	2	No	Yes
Red hand-held distress flare	2	No	Yes
EPIRB	1	No	Yes, but only if vessel is more than 2 nautical miles from nearest shore
Fire extinguisher (F1)	(F2)	Yes	Yes
Fresh drinking water	2 litres per person	No	Yes
Marine radio	1	No	Yes, but only if vessel is more than 2 nautical miles from nearest shore
Paddles or oars/rowlocks	(P1)	Yes	Yes
Sound signal (airhorn/whistle/bell)	1	Yes	Yes
V-sheet (distress signal)	1	No	Yes
Waterproof torch	1	Yes	Yes

Key.

- (B1): To be provided on vessels with covered bilges or closed under-floor compartments other than airtight void spaces. For all other vessels a bailer is to be carried.
- (B2): Is to be capable of draining each compartment (other than airtight void spaces). May require more than one bilge pump to be fitted.
- (F1): All vessels with an electric start motor, gas installation, fuel stove or battery.
- (F2): At least one. More are to be carried if potential sources of fire and the size of the vessel require it.
- (P1): Paddles or oars/rowlocks are to be carried on boats under 6 metres in length unless a second means of propulsion is fitted.

Part 2 Modified requirements for specified vessels

1 Modified requirements for safety equipment in relation to sailing vessels

- (1) A sailing vessel, less than 6 metres in length and operating on enclosed waters, is not required to carry an anchor.
- (2) A sailing vessel with a permanently enclosed, self draining hull is not required to carry a bucket or bailer.
- (3) A sailing vessel engaged in a sail training session organised by a club, school or other similar organisation is not required to carry safety equipment specified in Part 1 if a power-driven vessel, capable of use for rescue purposes, is in attendance.

2 Modified safety equipment requirements for certain vessels less than 6 metres

- (1) A vessel of less than 6 metres in length, with two or more independent means of propulsion, is not required to carry a paddle or a pair of oars.
- (2) For the purposes of subclause (1), two or more sails, are considered to be one means of propulsion.

3 Modified safety equipment requirements for certain small tenders

- (1) This clause applies to tenders that:
 - (a) are operating on enclosed waters, and
 - (b) are operating within 200 metres of the shore, and
 - (c) are less than 3 metres in length.
- (2) A tender to which this clause applies is not required to carry safety equipment specified in Part 1 if the tender carries the following safety equipment:
 - (a) a paddle or a pair of oars,
 - (b) a waterproof torch if operating between sunset and sunrise,
 - (c) a bucket, bailer or bilge pump.

4 Modified safety equipment requirements for personal watercraft, kayaks and canoes on open waters

A personal watercraft, kayak or canoe (other than an outrigger canoe) on open waters is not required to carry safety equipment specified in Part 1.

5 Modified safety equipment requirements for rowboats, dinghies and inflatable boats

A row boat, dinghy or inflatable boat is not required to carry safety equipment specified in Part 1 if the vessel is:

- (a) less than 3 metres in length, and
- (b) not a tender, and
- (c) not carrying an engine or fuel, and
- (d) not more than 200 metres from the nearest shore, and
- (e) operating between sunrise and sunset, and
- (f) operating on enclosed waters, and
- (g) built so as to float if swamped or capsized.

6 Modified safety equipment requirements for off-the-beach vessels

An off-the-beach vessel is not required to carry safety equipment specified in Part 1 if the vessel does not have sufficient storage room to carry the safety equipment specified in that Part in relation to the vessel.

7 Modified safety equipment requirements for outrigger canoes

- (1) An outrigger canoe is not required to carry safety equipment specified in Part 1 while operating on open waters if:
 - (a) each person on board has undergone a safety drill in respect of possible emergencies arising on the vessel, and
 - (b) the vessel is operating between sunrise and sunset, and
 - (c) the vessel is built so as to float if swamped or capsized, and
 - (d) the vessel is returned to shore or a safe haven if the weather or water conditions become, or are predicted to become, unsuitable for canoeing, and
 - (e) the vessel is carrying the following equipment:
 - (i) an appropriate lifejacket for each person on board,
 - (ii) flares or a mobile telephone (in a water tight container),
 - (iii) if the vessel is an outrigger canoe that carries 3 or more persons:
 - (A) at least 2 buckets (bailers) with a lanyard attached to each, and
 - (B) at least one spare paddle, and
 - (C) a rope of at least 25 metres in length and 12 millimetres in diameter of the type known as “silver rope”, securely attached to the forward canoe spreader or lashing point (the “wae”) for towing,
 - (iv) if the vessel is an outrigger canoe that carries less than 3 persons, a leg rope.
- (2) An outrigger canoe is not required to carry safety equipment specified in Part 1 while operating on enclosed waters if:
 - (a) each person on board has undergone a safety drill in respect of possible emergencies arising on the vessel, and
 - (b) the vessel is displaying a white strobe light on a one metre pole or 2 fixed white lights, one mounted at each end of the canoe, when operating between sunset and sunrise if that vessel is an outrigger canoe that carries 3 or more persons, and
 - (c) the vessel has 1 all round white light affixed to the highest point of the vessel, when operating between sunset and sunrise, if that vessel is an outrigger canoe that carries less than 3 persons, and
 - (d) the vessel is built so as to float if swamped or capsized, and
 - (e) the vessel is returned to shore or a safe haven if the weather or water conditions become, or are predicted to become, unsuitable for canoeing, and
 - (f) the vessel is carrying the following equipment:
 - (i) an appropriate lifejacket for each person on board,
 - (ii) flares or a mobile telephone (in a water tight container), where the vessel is operating between sunset and sunrise,
 - (iii) if the vessel is an outrigger canoe that carries 3 or more persons:
 - (A) at least 2 buckets (bailers) with a lanyard attached to each, and
 - (B) at least one spare paddle, and

public consultation draft

Marine Safety Regulation 2015 [NSW]
Schedule 8 Minimum safety equipment to be carried on recreational vessels

- (C) a rope of at least 25 metres in length and 12 millimetres in diameter of the type known as “silver rope”, securely attached to the forward canoe spreader or lashing point (the “wae”) for towing,
- (iv) if the vessel is an outrigger canoe that carries less than 3 persons, a leg rope.

8 Modified safety equipment requirements for dragon boats in enclosed waters

A dragon boat is not required to carry safety equipment specified in Part 1 while operating on enclosed waters if:

- (a) each person on board has undergone a safety drill in respect of possible emergencies arising on the vessel, and
- (b) the vessel is displaying appropriate lights when operating between sunset and sunrise, and
- (c) the vessel is operating not more than 400 metres from the nearest shore, and
- (d) the vessel is built so as to float if swamped or capsized, and
- (e) the vessel is returned to shore or a safe haven if the weather or water conditions become, or are predicted to become, unsuitable for boating, and
- (f) the vessel is not rowed in the middle of a channel and is rowed on the starboard side (bow side) of the channel, and
- (g) the vessel is carrying the following equipment:
 - (i) at least 1 bucket (bailer) with a lanyard attached,
 - (ii) a rope of at least 25 metres in length and 12 millimetres in diameter of the type known as “silver rope”, securely attached to the dragon boat for towing,
 - (iii) flares or a mobile telephone (in a water tight container) when the vessel is operating between sunset and sunrise.

public consultation draft

Marine Safety Regulation 2015 [NSW]
Schedule 9 Standard of safety equipment carried on recreational vessels

Schedule 9 Standard of safety equipment carried on recreational vessels

(Clause 118 (2))

Item of equipment	Minimum standard required
Anchor with chain and/or line	<p>The anchor and chain and/or line must be suitable for the purpose of securing the vessel given the vessel's size, weight and the area of operation.</p> <p>The chain and/or line must be of sufficient strength and durability for the purpose and is to be securely attached to both the anchor and the vessel.</p> <p>Where applicable, the anchor should comply with Australian Standard AS 2198—1983, <i>Anchors for small boats</i> (as in force from time to time).</p>
Appropriate chart	<p>An Australian Navigational Chart showing the area(s) proposed for the vessel's voyage, whether in printed or digital format, that can be readily displayed for the duration of the voyage.</p>
Appropriate map	<p>A clearly legible map(s) (whether in printed or digital format) of the area proposed for the vessel's voyage or excursion showing significant features for navigation such as shallows, reefs, hazards and channels by figures, colours or shading.</p>
Bailer with lanyard	<p>A bailer must be suitable for bailing water from the vessel and have a lanyard (rope) securely attached. The bailer must be readily accessible and not used for any other purpose. The lanyard must be of a length to allow the bailer to be cast over the side of the vessel and retrieved.</p> <p>A fire bucket carried in accordance with this standard may double as a bailer provided it satisfies the above requirements.</p>
Bilge pump	<p>The pump or pumps carried must be capable of draining each compartment of the vessel. They may be either manual or power operated, and must have a strainer fitted to the suction pipe. The strainer must be of a sufficiently small mesh size to prevent choking of the pump.</p>
Bucket with lanyard	<p>The bucket must be suitable for bailing water out of the vessel, as well as collecting water for use in case of fire. The bucket must be manufactured from metal or a robust plastic or robust canvas (for example, a Wallaby bucket), and be designed so as not to collapse, distort or lose the handle when full of water. The bucket must not be used for any other purpose and must be readily available at all times.</p> <p>The bucket must have a lanyard (rope) attached of significant length to allow the bucket to be cast over the side and retrieved full of water.</p>
Compass	<p>The compass must be liquid damped with a rotating card showing the cardinal points.</p>

public consultation draft

Marine Safety Regulation 2015 [NSW]
Schedule 9 Standard of safety equipment carried on recreational vessels

Item of equipment	Minimum standard required
EPIRB	<p>An Emergency Position Indicating Radio Beacon (EPIRB) suitable for marine use, must transmit on 406 MHz and conform with Australian and New Zealand Standard AS/NZS 4280.1:2003, <i>406 MHz satellite distress beacons—Marine emergency position-indicating radio beacons (EPIRBs) (IEC 61097-2:2002, MOD</i> (as in force from time to time)</p> <p>Any 406 MHz EPIRB must be properly registered with the Australian Maritime Safety Authority (AMSA).</p>
Fire extinguisher	<p>Fire extinguishers carried must be of a type suitable for the type of fuel carried on board the vessel as specified in Australian Standard AS 1799.1—2009, <i>Small craft—Part 1: General requirements for power boats</i> (as in force from time to time). They must be designed and manufactured in accordance with an Australian Standard specification for portable fire extinguishers.</p> <p>Extinguishers must be stowed, so as to be readily accessible in the case of fire.</p>
Lifejacket Level 50S or greater	<p>A lifejacket that meets:</p> <ul style="list-style-type: none">(a) performance standard 50S, 50, 100, 150 or 275 of Australian Standard AS 4758 <i>Lifejackets</i> (as in force from time to time), or(b) any standard or specifications approved by RMS.
Lifejacket Level 100 or greater	<p>A lifejacket that meets:</p> <ul style="list-style-type: none">(a) performance standard 100, 150 or 275 of Australian Standard AS 4758 <i>Lifejackets</i> (as in force from time to time), or(b) any standard or specifications approved by RMS.

public consultation draft

Marine Safety Regulation 2015 [NSW]
Schedule 9 Standard of safety equipment carried on recreational vessels

Item of equipment	Minimum standard required
Marine radio	<p>A 27 MHz, HF or VHF marine radio transceiver approved by the Australian Communications and Media Authority (ACMA).</p> <p>In addition, for vessels operating within the coverage area of VHF service, the VHF transceiver must be of international maritime type complying with Australian/New Zealand Standard AS/NZS 4415.1:2003, <i>Radiotelephone transmitters and receivers for the maritime mobile service operating in the VHF bands—Technical characteristics and methods of measurement—Part 1: Shipborne equipment and limited coast stations (including DSC) (IEC 61097-7:1996, MOD)</i> (as in force from time to time).</p> <p>In addition, for vessels operating outside the coverage area of VHF service, at least one of the following options (in descending order of capability) must be selected by the operator based on the availability of services in the area of operation:</p> <ul style="list-style-type: none">(a) GMDSS-compatible Inmarsat C terminal,(b) MF/HF transceiver (non-DSC) plus marine satellite telephone,(c) mobile telephone service (satellite, CDMA or GSM) appropriate for use in the marine environment, Note. This option is for vessels that may operate occasionally outside of VHF range as the minimum equipment needed to provide distress and safety communications. It is not considered as capable an option as (a) or (b) above.(d) Class 1 MF/HF transceiver complying with GMDSS Sea Area A3 requirements as per provision iv/10.1.2 of the Safety Convention and the <i>Navigation Act 2012</i> of the Commonwealth. Note. This option is normally only available to larger vessels that can satisfy higher transmitter power and antenna performance requirements.
Oars (pair) with rowlocks	A pair of oars that must be capable of being used to row the vessel in which they are carried.
Orange smoke hand-held distress signal	An orange smoke hand-held distress signal that complies with Australian Standard AS 2092—2004, <i>Pyrotechnic marine distress flares and signals for pleasure craft</i> (as in force from time to time) as it relates to such distress signals.
Paddle	A paddle that is capable of being used to row the vessel in which it is carried.
Red hand-held distress flare	A red hand-held distress flare that complies with Australian Standard AS 2092—2004, <i>Pyrotechnic marine distress flares and signals for pleasure craft</i> (as in force from time to time) as it relates to such distress signals.

public consultation draft

Marine Safety Regulation 2015 [NSW]
Schedule 9 Standard of safety equipment carried on recreational vessels

Item of equipment

Minimum standard required

V-sheet (distress signal)

A fluorescent orange-red coloured sheet of dimensions not less than 1.8 metres \times 1.2 metres with a black V superimposed on the sheet in the position shown. The letter "V" on the sheet must be of a width no more than 150 millimetres. Lanyard (rope) must be tied to each corner of the sheet.

Figure

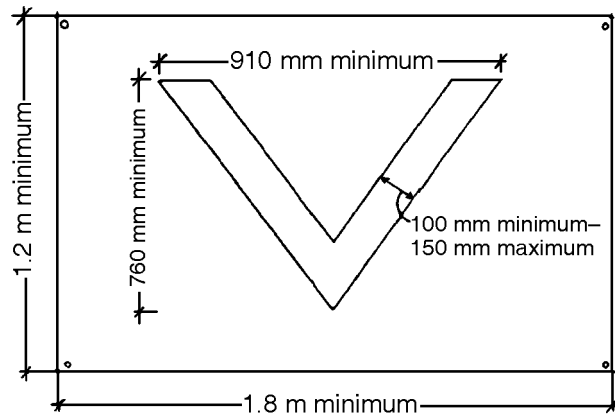

Waterproof torch

A water resistant, floating type torch in operational order that is capable of being used to signal.

Schedule 10 Coastal bars

(Clause 3)

Name of coastal bar	General description of bar location
Bellinger River	Located near the town of Urunga in the vicinity of the confluence of the Bellinger and Kalang Rivers and the Tasman Sea.
Boambee Creek	Located near the town of Toormina in the vicinity of the confluence of Boambee Creek with the Tasman Sea.
Bonville Creek	Located near the town of Sawtell in the vicinity of the confluence of Bonville Creek with the Tasman Sea.
Brisbane Water	Located near the town of Umina in the vicinity of the confluence of Brisbane Water with Broken Bay and west of the port hand lateral markers.
Brunswick River	Located near the town of Brunswick Heads in the vicinity of the confluence of the Brunswick River with the Coral Sea.
Burrill Lake	Located near the town of Dolphin Point in the vicinity of the confluence of Burrill Lake with the Tasman Sea.
Camden Haven River	Located near the town of North Haven in the vicinity of the confluence of the Camden Haven Inlet with the Tasman Sea.
Clarence River	Located near the town of Yamba in the vicinity of the confluence of the Clarence River with the Coral Sea.
Clyde River	Located near the town of Batemans Bay in the vicinity of the confluence of the Clyde River and Batemans Bay.
Corindi River	Located near the town of Red Rock in the vicinity of the confluence of the Corindi River with the Tasman Sea.
Crookhaven River	Located near the town of Crookhaven in the vicinity of the confluence of the Crookhaven River with the Tasman Sea.
Cudgen Creek	Located near the town of Kingscliff in the vicinity of the confluence of Cudgen Creek with the Coral Sea.
Cudgera Creek	Located near the town of Hastings Point in the vicinity of the confluence of Cudgera Creek with the Coral Sea.
Currarong Creek	Located near the town of Currarong in the vicinity of the confluence of Currarong Creek with the Tasman Sea.
Durras Lake	Located near the town of Durras North in the vicinity of the confluence of Durras Lake with the Tasman Sea.
Evans River	Located near the town of Evans Head in the vicinity of the confluence of the Evans River with the Coral Sea.
Hastings River	Located near the town of Port Macquarie in the vicinity of the confluence of the Hastings River with the Tasman Sea.
Kianinny Bay	Located near the town of Tathra in the vicinity of the confluence of Kianinny Bay with the Tasman Sea.
Killick Creek	Located near the town of Crescent Head in the vicinity of the confluence of Killick Creek with the Tasman Sea.
Korogoro Creek	Located near the town of Hat Head in the vicinity of the confluence of Korogoro Creek with the Tasman Sea.

public consultation draft

Marine Safety Regulation 2015 [NSW]
Schedule 10 Coastal bars

Name of coastal bar	General description of bar location
Lake Conjola	Located near the town of Lake Conjola in the vicinity of the confluence of Lake Conjola with the Tasman Sea.
Lake Illawarra	Located near the town of Warilla in the vicinity of the confluence of Lake Illawarra with the Tasman Sea.
Macleay River	Located near the town of South West Rocks in the vicinity of the confluence of the Macleay River with the Tasman Sea.
Manning River	Located near the town of Harrington in the vicinity of the confluence of the Manning River with the Tasman Sea.
Manning River	Located near the town of Old Bar in the vicinity of the confluence of Farquhar Inlet with the Tasman Sea.
Merimbula Lake	Located near the town of Merimbula in the vicinity of the confluence of Merimbula Lake with the Tasman Sea.
Minnamurra River	Located near the town of Minnamurra in the vicinity of the confluence of the Minnamurra River with the Tasman Sea.
Mogareka Inlet	Located approximately 2 km north of the town of Tathra in the vicinity of the confluence of Mogareka Inlet with the Tasman Sea.
Mooball Creek	Located near the town of Pottsville in the vicinity of the confluence of Mooball Creek with the Coral Sea.
Moonee Creek	Located near the town of Moonee Beach in the vicinity of the confluence of Moonee Creek with the Tasman Sea.
Moruya River	Located near the town of Moruya Heads in the vicinity of the confluence of the Moruya River with the Tasman Sea.
Nambucca River	Located near the town of Nambucca Heads in the vicinity of the confluence of the Nambucca River with the Tasman Sea.
Narrawallee Inlet	Located near the town of Narrawallee in the vicinity of the confluence of Narrawallee Inlet with the Tasman Sea.
Pambula River	Located near the town of Pambula Beach in the vicinity of the confluence of the Pambula River with the Tasman Sea.
Richmond River	Located near the town of East Ballina in the vicinity of the confluence of the Richmond River with the Coral Sea.
Sandon River	Located near the town of Sandon in the vicinity of the confluence of the Sandon River with the Coral Sea.
South West Rocks Creek	Located near the town of South West Rocks in the vicinity of the confluence of South West Rocks Creek with the Tasman Sea.
Sussex Inlet	Located near Jervis Bay and Cudmirrah National Parks in the vicinity of the confluence of Sussex Inlet with the Tasman Sea.
Swansea Channel	Located near the suburb of Swansea in the vicinity of the confluence of Lake Macquarie's Swansea Channel with the Tasman Sea.
Tomaga River	Located near the towns of Mossy Point and Tomakin in the vicinity of the confluence of the Tomaga River with the Tasman Sea.
Tuross Inlet	Located near the town of Tuross Head in the vicinity of the confluence of Tuross Lake with the Tasman Sea.

public consultation draft

Marine Safety Regulation 2015 [NSW]
Schedule 10 Coastal bars

Name of coastal bar	General description of bar location
Tweed River	Located near the town of Tweed Heads in the vicinity of the confluence of the Tweed River with the Coral Sea.
Tuggerah Lake	Located near the town of The Entrance in the vicinity of the confluence of Tuggerah Lake with the Tasman Sea.
Wagonga Inlet	Located near the town of Narooma in the vicinity of the confluence of the Wagonga Inlet with the Tasman Sea.
Wallis Lake	Located near the towns of Forster-Tuncurry in the vicinity of the confluence of Wallis Lake with the Tasman Sea.
Wonboyn River	Located near the town of Wonboyn in the vicinity of the confluence of the Wonboyn River with the Tasman Sea.
Wooli River	Located near the town of Wooli in the vicinity of the confluence of the Wooli River with the Coral Sea.

public consultation draft

Marine Safety Regulation 2015 [NSW]
Schedule 11 Penalty notice offences—offences under Marine Safety Act 1998

Schedule 11 Penalty notice offences—offences under Marine Safety Act 1998

(Clause 133 (1))

Column 1—Offences	Column 2— Level of penalty
Offences under the Marine Safety Act 1998	
Section 10 (3) in respect of a contravention of Part B or Part C of the <i>International Regulations for Preventing Collisions at Sea 1972</i>	2
Section 10 (3) in respect of a contravention of Part D of the <i>International Regulations for Preventing Collisions at Sea 1972</i>	1
Section 11 (4) exceed notified speed limit by less than 10 knots where vessel concerned is not a personal watercraft	1
Section 11 (4) exceed notified speed limit by less than 10 knots where vessel concerned is a personal watercraft	2
Section 11 (4) exceed notified speed limit by 10 knots or more where vessel concerned is not a personal watercraft	2
Section 11 (4) exceed notified speed limit by 10 knots or more where vessel concerned is a personal watercraft	3
Section 11 (4) create wash in contravention of notice	3
Section 11 (4) any other contravention of notice	2
Section 12 (6)	3
Section 13 (1) (a) where vessel concerned is a commercial vessel	5
Section 13 (1) (a) where vessel concerned in a recreational vessel	3
Section 13 (2)	3
Section 15, 15A (2) or 16 (2)	3
Section 32	1
Section 35 (1) or (2)	3
Section 45 (1) or (2), 47 (1), (2) or (3)	5
Section 47 (4)	2
Section 51 (1) or (2)	3
Section 63 where vessel concerned is not a personal watercraft	2
Section 63 where vessel concerned is a personal watercraft—first offence	3
Section 63 where vessel concerned is a personal watercraft—second or subsequent offence	4
Section 91 (1)	5
Section 91 (2)	3
Section 92 (5) or 97 (4)	1
Section 102 (a)	3
Section 125 (2)	3

public consultation draft

Marine Safety Regulation 2015 [NSW]
Schedule 11 Penalty notice offences—offences under Marine Safety Act 1998

Column 1—Offences	Column 2— Level of penalty
Section 125D or 125E (3)	5
Offences under this Regulation	
Clause 6 (1), (2) or (3)	3
Clause 7 (1), (2) or (3)	3
Clause 8 (2), (3), (4) or (5)	2
Clause 8 (6) or (7)	2
Clause 9 (4)	2
Clause 10 (1)	2
Clause 10 (2)	2
Clause 11 (1)	1
Clause 11 (2)	2
Clause 12 (1)	3
Clause 13	3
Clause 14	1
Clause 15 (1) or (2)	1
Clause 17	2
Clause 18	2
Clause 19	2
Clause 20 (1) or (2)	2
Clause 21 (1), (3) or (4)	2
Clause 22 (1), (3) or (4)	2
Clause 24	1
Clause 25	2
Clause 26 (1) or (2)	1
Clause 27 (1)	1
Clause 28 (1)	5
Clause 29	5
Clause 30	5
Clause 31 (1) or (2)	3
Clause 33 (2), 28 (2) or 29 (2)	3
Clause 36 (2)	3
Clause 38 (1) where vessel concerned is not a personal watercraft	1
Clause 38 (1) where vessel concerned is a personal watercraft	2
Clause 38 (2) where vessel concerned is not a personal watercraft	1
Clause 38 (2) where vessel concerned is a personal watercraft	2
Clause 38 (3)	1

public consultation draft

Marine Safety Regulation 2015 [NSW]
Schedule 11 Penalty notice offences—offences under Marine Safety Act 1998

Column 1—Offences	Column 2— Level of penalty
Clause 39 (1) where vessel operated is not a personal watercraft	1
Clause 39 (1) where vessel operated is a personal watercraft	2
Clause 39 (2) where vessel operated is not a personal watercraft	1
Clause 39 (2) where vessel operated is a personal watercraft	2
Clause 39 (3) where vessel operated is not a personal watercraft	1
Clause 39 (3) where vessel operated is a personal watercraft	2
Clause 40	1
Clause 41	2
Clause 42 or 43 (1)	2
Clause 44 (1) where vessel operated is not a personal watercraft	2
Clause 44 (1) where vessel operated is a personal watercraft	3
Clause 44 (3)	2
Clause 45	2
Clause 46 (1) or 41 (1)	1
Clause 48 (1) first offence	2
Clause 48 (1) second or subsequent offence	3
Clause 48 (2)	3
Clause 49 (1) or (2)	2
Clause 50 (1)	3
Clause 50 (2)	2
Clause 51 (1) or (7) (a)	1
Clause 51 (7) (b)	2
Clause 52	3
Clause 53 (2)	3
Clause 55 (1)	3
Clause 56 (1)	3
Clause 57 (1)	3
Clause 57 (2)	3
Clause 58	3
Clause 62, 65 (2) or (3), 66 or 67	3
Clause 74 (7)	1
Clause 77, 78 (1) or 80 (2)	1
Clause 81 (1) or (2)	2
Clause 85 (2)	3
Clause 86	3
Clause 87 (1) or (2) or 90 (1), (2) or (5) (a)	1

public consultation draft

Marine Safety Regulation 2015 [NSW]
Schedule 11 Penalty notice offences—offences under Marine Safety Act 1998

Column 1—Offences	Column 2— Level of penalty
Clause 88	1
Clause 90 (5) (b)	2
Clause 91	1
Clause 92	3
Clause 93	3
Clause 94 (1)	5
Clause 100 (1)	3
Clause 100 (2)	2
Clause 103	1
Clause 114 (1)	3
Clause 114 (2)	3
Clause 115 (1)	3
Clause 115 (2)	3
Clause 116 (1) or (2)	2
Clause 118 (1), (2), (3), (4), (5), (6), (7), (8) or (10)	2
Clause 120 (2) or (3)	2
Clause 121 (1) or (2)	2
Clause 122 (1) or (4)	2
Clause 124 (2)	2
Clause 125 (1) or (2)	2
Clause 126	2
Clause 128 (2)	1
Clause 128 (3)	3
Clause 129	2
Clause 132 (1)	2
Clause 132 (3)	5
Clause 133 (1), (2) or (3)	2
Clause 136	3

Schedule 12 Penalty notice offences—offences under Marine Pollution Act 2012

(Clause 133 (2))

Column 1—Offences	Column 2— Level of penalty for natural persons	Column 3— Level of penalty for corporations
Offences under the Marine Pollution Act 2012		
Section 15 (1)	6	6
Section 16 (1)	6	-
Section 16 (2)	6	6
Section 17	6	6
Section 26 (1)	6	6
Section 27 (1)	4	5
Section 28	4	5
Section 29 (1)	6	6
Section 30 (1)	6	-
Section 30 (2)	6	6
Section 31	6	6
Section 43 (1)	2	3
Section 44	2	3
Section 45 (1)	5	6
Section 46 (1)	5	-
Section 46 (2)	5	6
Section 47	5	6
Section 53 (1)	5	6
Section 54 (1)	5	-
Section 54 (2)	5	6
Section 55	5	6
Section 60 (1)	5	6
Section 61 (1)	5	-
Section 61 (2)	5	6
Section 62	5	6
Section 68 (1) or (2)	5	6
Section 69 (1) or (2)	5	6
Section 70 (1) or (2)	5	6
Section 71 (1) or (2)	5	6
Section 72 (2)	5	6

public consultation draft

Marine Safety Regulation 2015 [NSW]
Schedule 12 Penalty notice offences—offences under Marine Pollution Act 2012

Column 1—Offences	Column 2— Level of penalty for natural persons	Column 3— Level of penalty for corporations
Section 73	5	6
Section 74 (1) or (2)	5	5
Section 78 (1)	4	4
Section 79	4	4
Section 80	4	5
Section 81	4	5
Section 82	4	4
Section 87 (1)	6	-
Section 88	6	-
Section 89	6	-
Section 90 (1) or (2)	6	6
Section 91 (1)	6	6
Section 92 (1) or (2)	6	6
Section 93	6	6
Section 95 (1)	5	5
Section 100 (1)	5	5
Section 104	4	4
Section 107 (1)	4	4
Section 110 (1)	4	4
Section 113 (1)	5	6
Section 116	4	-
Section 117 (1) or (2)	4	-
Section 119	4	-
Section 120	4	5
Section 121 (1) or (2)	4	5
Section 122	2	-
Section 124	4	5
Section 127	4	-
Section 128 (1) or (2)	4	-
Section 130	4	-
Section 131	4	5
Section 132 (1) or (2)	4	5
Section 133	3	-
Section 135 (1)	3	4
Section 136	3	4
Section 140	3	-

public consultation draft

Marine Safety Regulation 2015 [NSW]
Schedule 12 Penalty notice offences—offences under Marine Pollution Act 2012

Column 1—Offences	Column 2— Level of penalty for natural persons	Column 3— Level of penalty for corporations
Section 141 (1) or (2)	4	-
Section 143	4	-
Section 144	3	4
Section 145 (1) or (2)	3	4
Section 146	3	-
Section 150 (1)	4	-
Section 150 (2)	4	5
Section 150 (3)	1	1
Section 151 (1)	4	-
Section 151 (2)	4	5
Section 151 (3)	1	1
Section 152 (1)	4	-
Section 152 (2)	4	5
Section 152 (3)	1	1
Section 157	1	2
Section 158	1	2
Section 160	2	3
Section 161 (1)	2	3
Section 163	2	3
Section 164	2	3
Section 172 (1)	5	6
Section 174 (1)	5	6
Section 175	5	6
Section 177 (1)	5	6
Section 181	6	6
Section 187 (1)	5	6
Section 193 (4)	5	6
Section 195 (5)	5	5
Section 198	5	6
Section 200 (5)	5	5
Section 202	5	6
Section 209 (1)	5	6
Section 222 (1)	5	6
Section 231 (b)	5	5

Offences under the Marine Pollution Regulation 2014

public consultation draft

Marine Safety Regulation 2015 [NSW]
Schedule 12 Penalty notice offences—offences under Marine Pollution Act 2012

Column 1—Offences	Column 2— Level of penalty for natural persons	Column 3— Level of penalty for corporations
Clause 7 (2)	2	-
Clause 10 (2)	2	-
Clause 14 (1) or (2)	5	6
Clause 15 (2) or (3)	5	6
Clause 16	5	6
Clause 17	5	6
Clause 18	4	5
Clause 30	5	6
Clause 32	5	6
Clause 34 (1)	5	6
Clause 35	5	6
Clause 36 (1) or (2)	5	6
Clause 37 (3)	5	6
Clause 39 (2)	5	6
Clause 45 (1)	5	-
Clause 46 (1)	5	-
Clause 47 (1)	5	-
Clause 48 (1) or (2)	5	6
Clause 49 (1)	5	6
Clause 50 (1) or (2)	5	6
Clause 51	5	6